

SDO CEE307: Graphic Statics

Department of Civil & Environmental
Engineering, Stanford University

Acknowledgement: Lauren L. Beghini

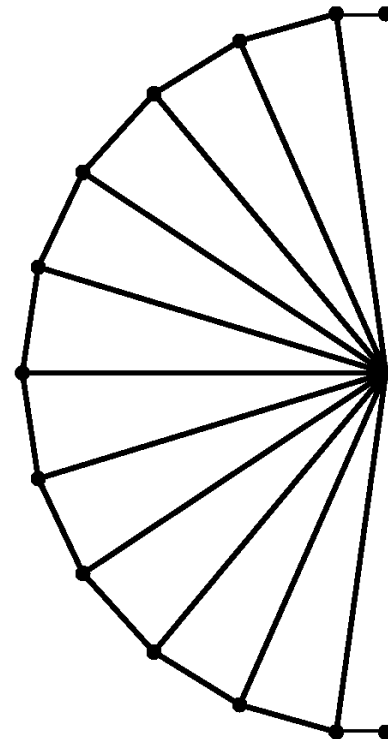
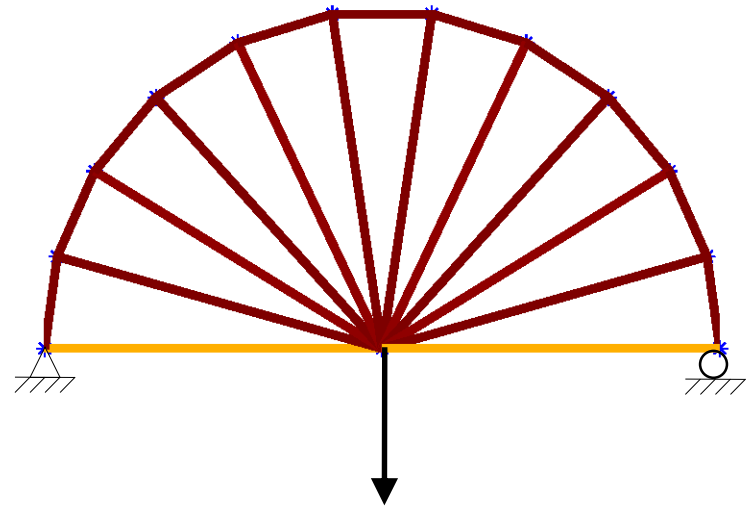

What is Graphic Statics?

- A way to graphically determine the member forces in a structure without a system of equations
- Can be used to analyze “unstable” structures that finite element analysis cannot
- Helpful in designing cable structures

History of Graphic Statics

- Composition of forces by Italians **Leonardo da Vinci** and **Galileo Galilei**.
- Dutch mathematician **Simon Stevin** (1548-1620) was the first person to represent force as a vector and the interpretation of the parallelogram of forces.
- **Isaac Newton** (1642-1727) formulated the laws of force and motion.
- Frenchman **Varignon** (1654-1722) presented the force polygon and the funicular polygon.
- **Maxwell** and **Taylor** (1864) published a graphical method for analyzing forces in trusses.
- **Cremona** (1872) demonstrated the graphical analysis of trusses.
- German engineer **Karl Culmann** (1821-1881) is generally acknowledged as the father of graphic statics – *Die Graphische Statik* (1866) was first comprehensive body of graphical techniques.
- Techniques influenced and used by **Koechlin** (Eiffel Tower co-designer), **Maillart**, **Menn**, **Nervi**, **Gaudi**, **Candela**, and **Calatrava**

GRAPHICAL ANALYSIS

A TEXT BOOK ON
GRAPHIC STATICS

BY

WILLIAM S. WOLFE, M.S.

*Head of Structural Department, Smith, Hinchman & Griggs. Formerly
Instructor in Architectural Engineering, University of Illinois.
Associate Member American Society of Civil Engineers.
Associate Member Society of Naval Architects
and Marine Engineers*

History of Graphic Statics

PREFACE

THIS book has been developed from notes and blue prints prepared by the writer and used in his classes at the University of Illinois. Certain additional material has been added, a part of which has been briefly presented in a number of articles contributed by the writer to the technical press. The notes referred to above were modeled after a set prepared by Dr. N. C. Ricker, several years before, to whom the writer is greatly indebted.

Many additional problems might have been added and the discussion greatly extended. This is especially true of Chapters IV and VII to X inclusive. However, it has been thought best to keep the book to smaller proportions, and the writer believes that a thorough mastery of the constructions and solutions here presented will give the student an excellent grasp of the subject.

Adding Force Vectors Graphically

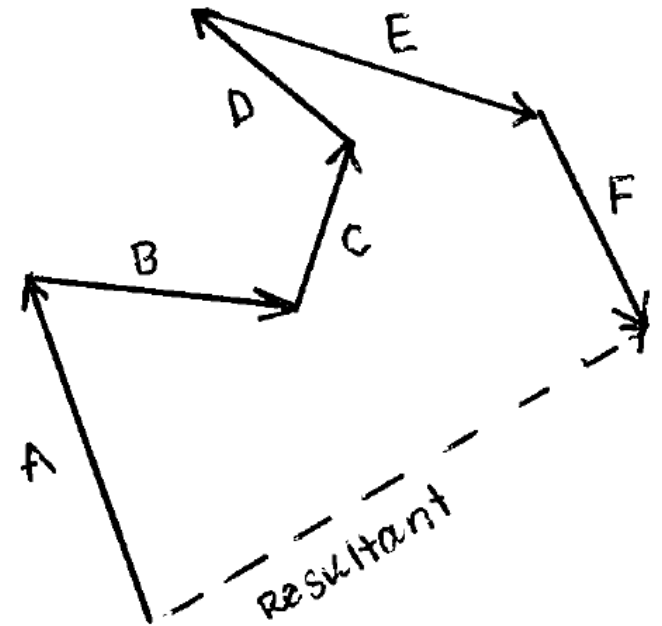
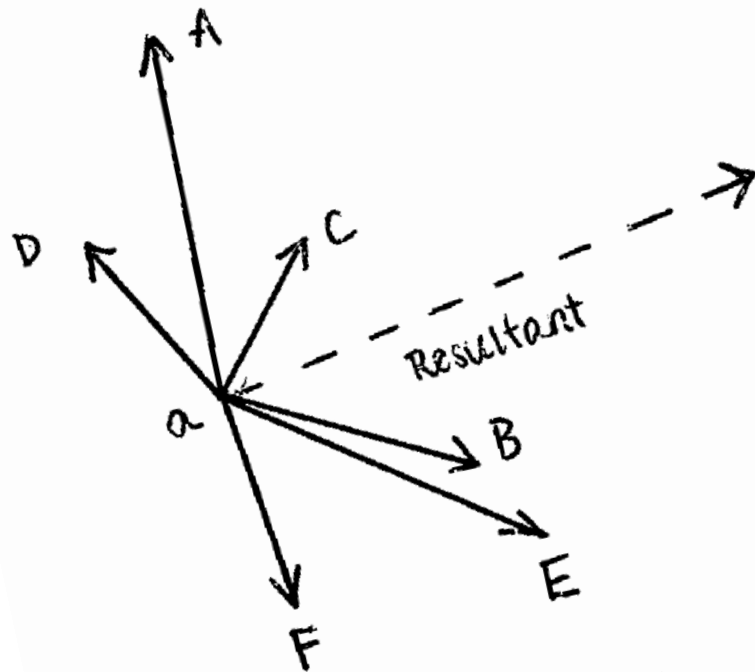

Force Polygon

Basic Diagrams and Interval Notation (Bow's Notation)

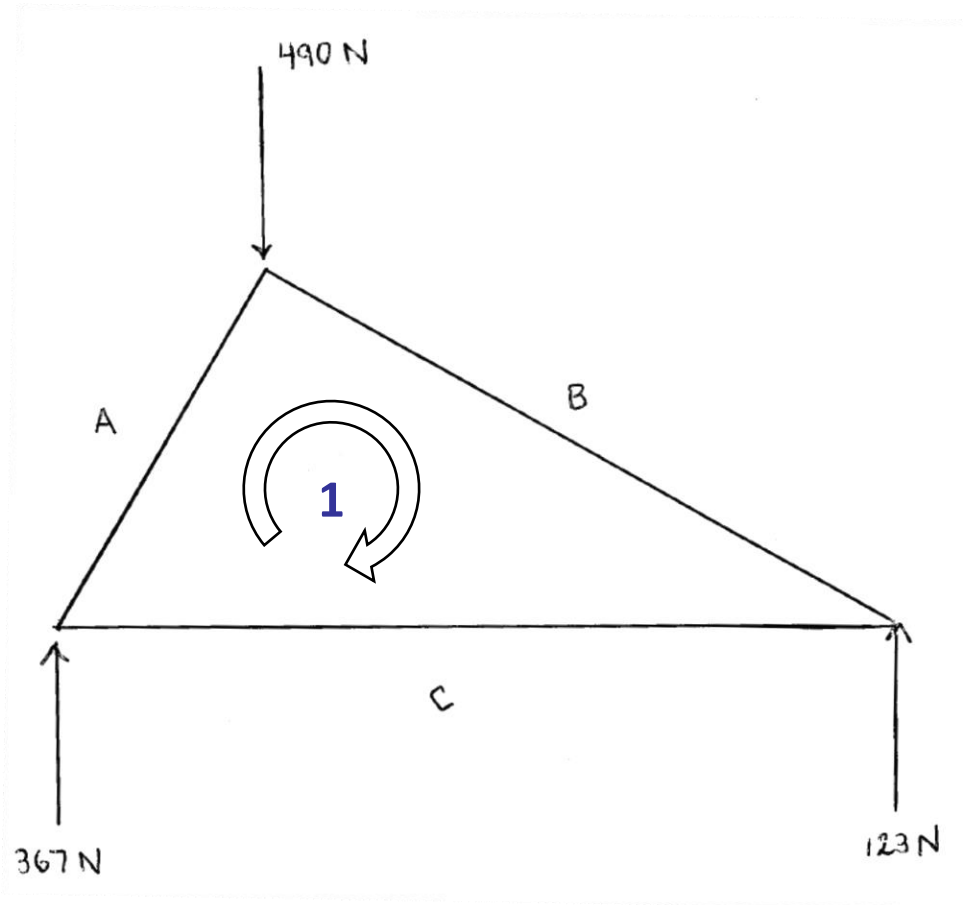

Joint is named by reading the letters and numbers that surround in a **clockwise sequence**

Graphical Analysis Procedure

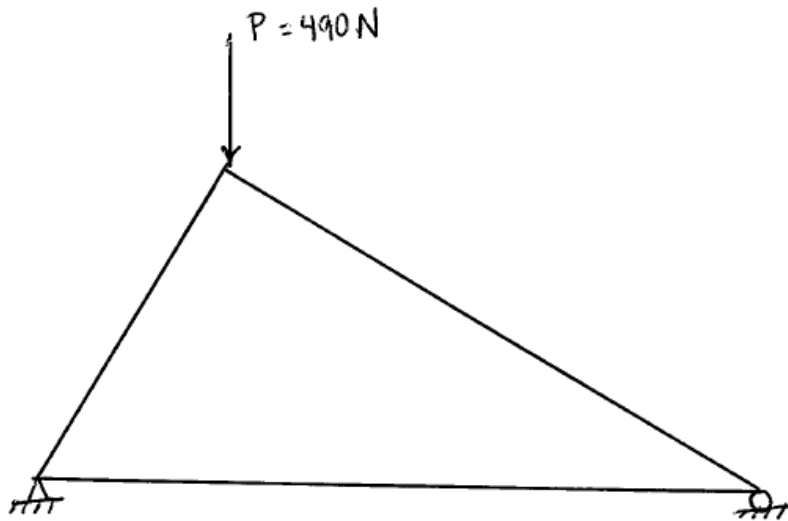

1. Solve for equilibrium reactions

Spanning Structures Statics, Zalewski and Allen 1998

Graphical Analysis Procedure

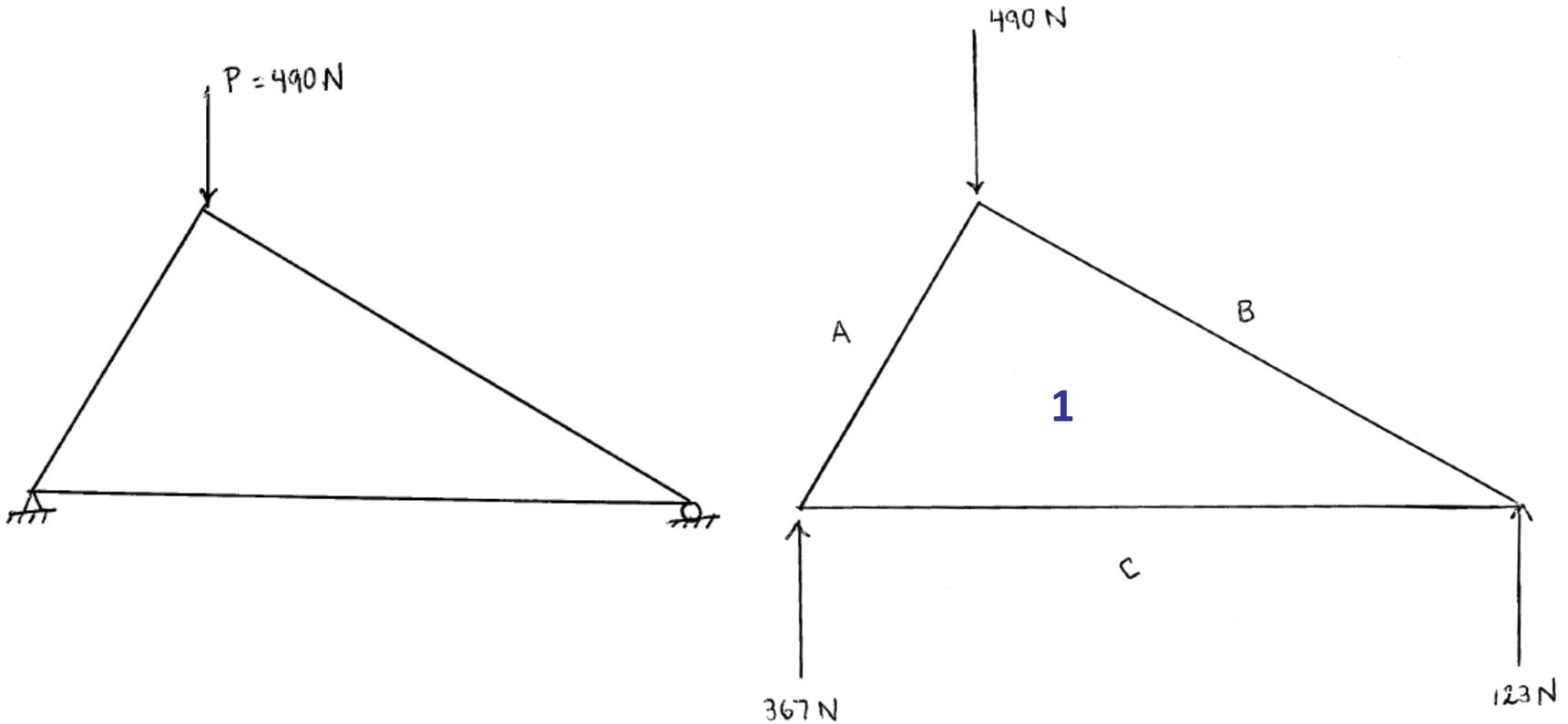

1. Solve for equilibrium reactions

2. Draw & label the form diagram

Graphical Analysis Procedure

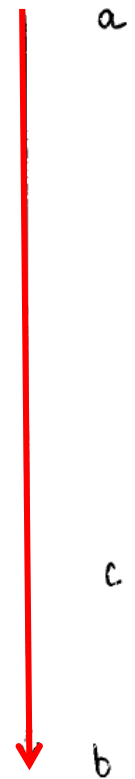
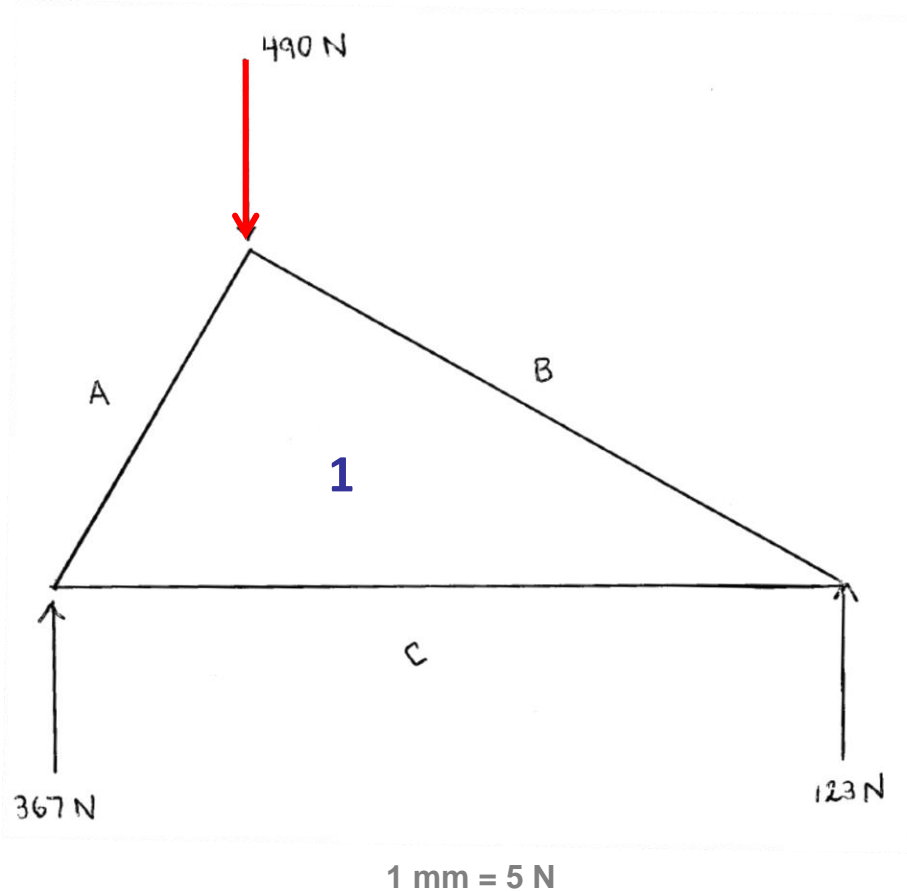

3. Draw the external force diagram to scale

Force Polygon

Graphical Analysis Procedure

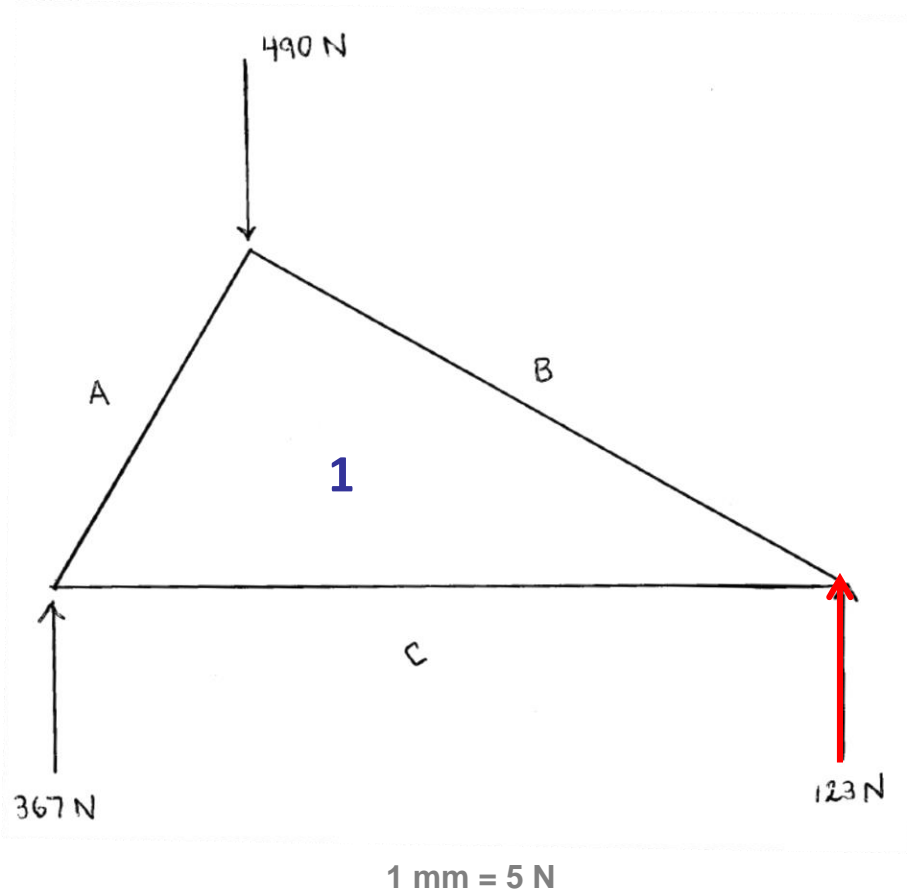

3. Draw the external force diagram to scale

Force Polygon

Graphical Analysis Procedure

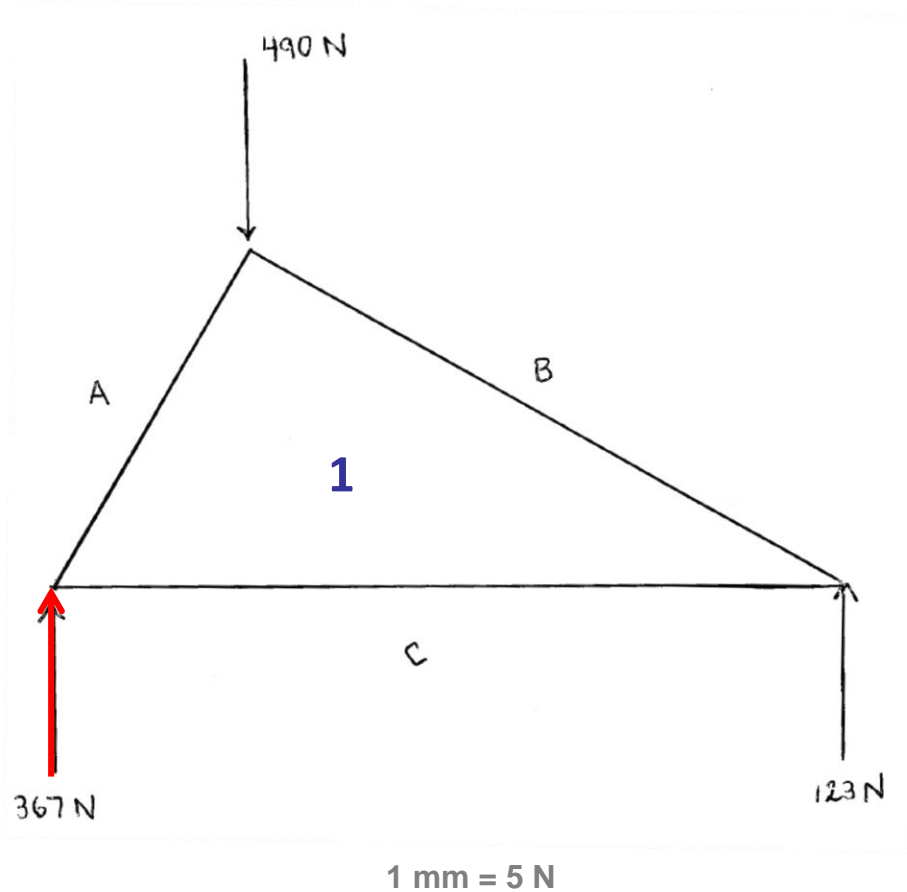

3. Draw the external force diagram to scale

Force Polygon

Graphical Analysis Procedure

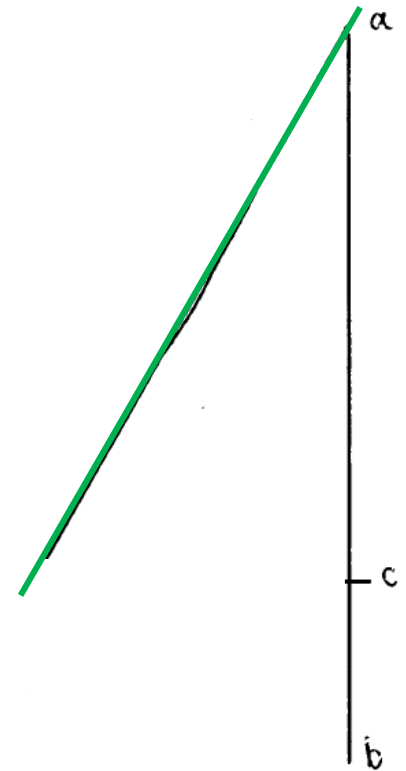
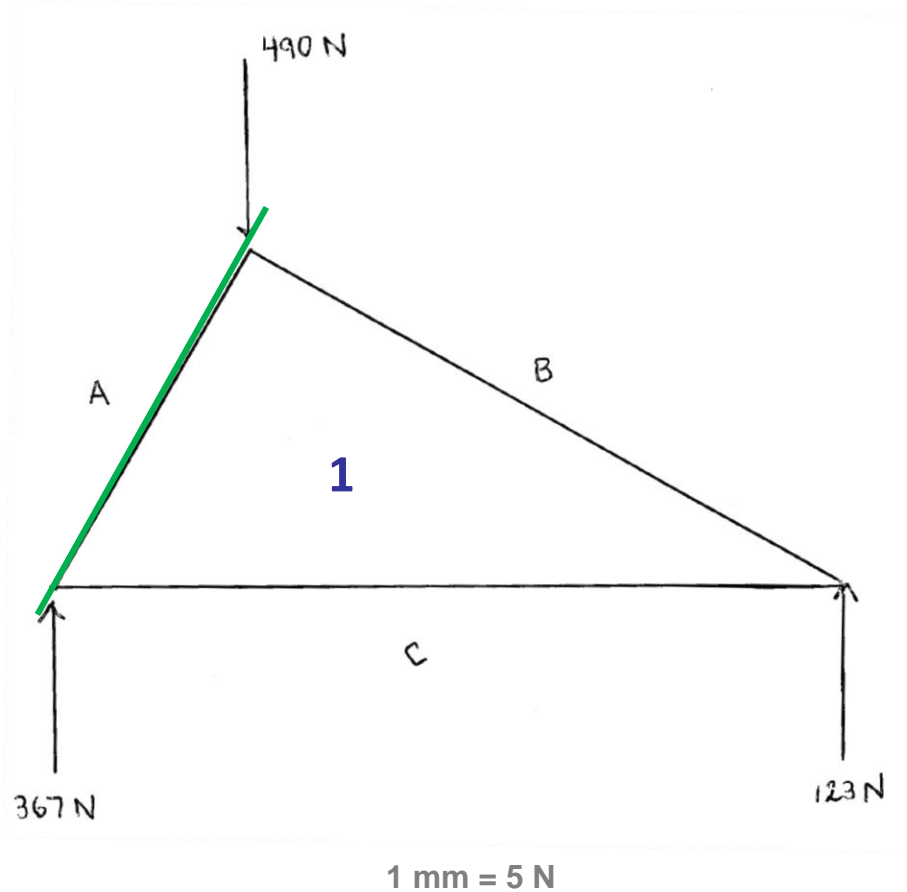

4. Find the unknown points

Graphical Analysis Procedure

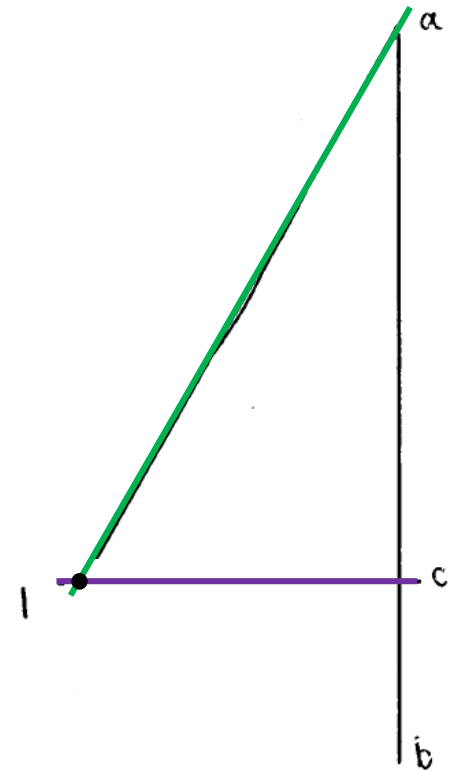
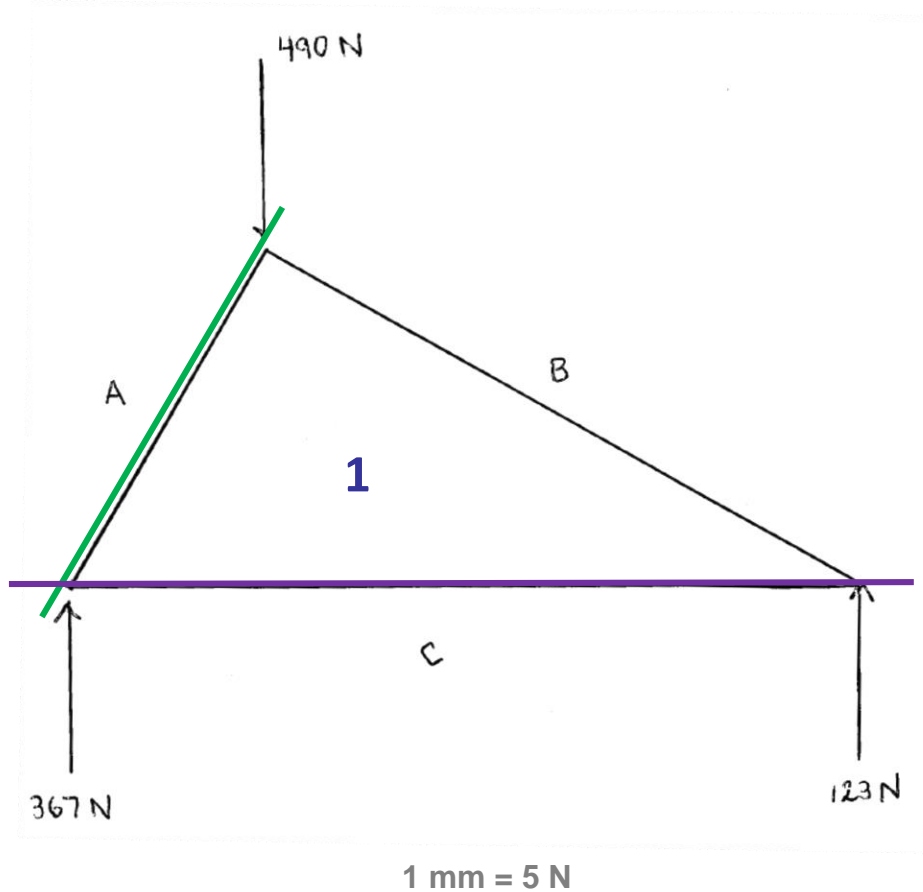

4. Find the unknown points

Graphical Analysis Procedure

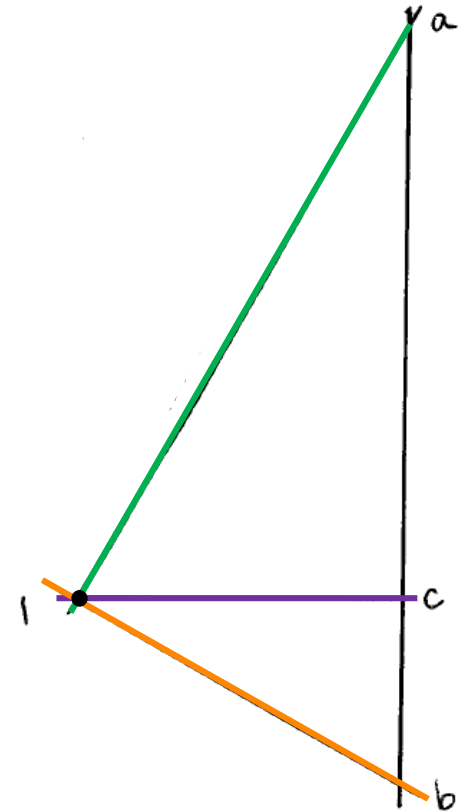
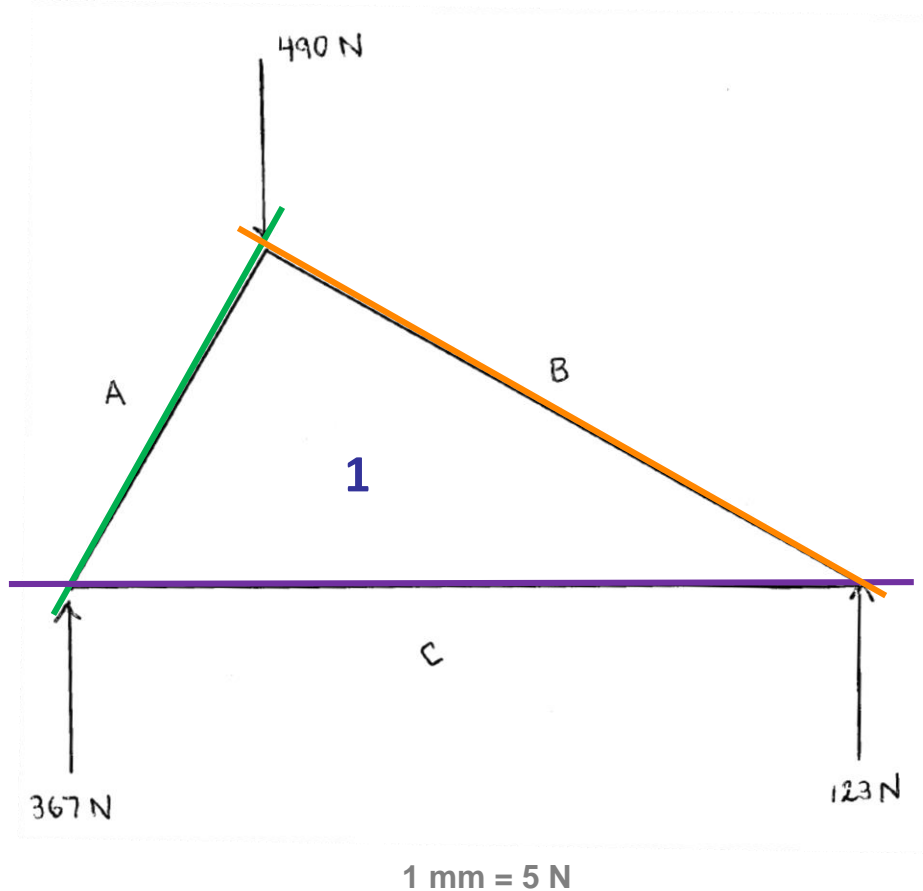

5. Finish the Force Diagram & measure member forces

Graphical Analysis Procedure

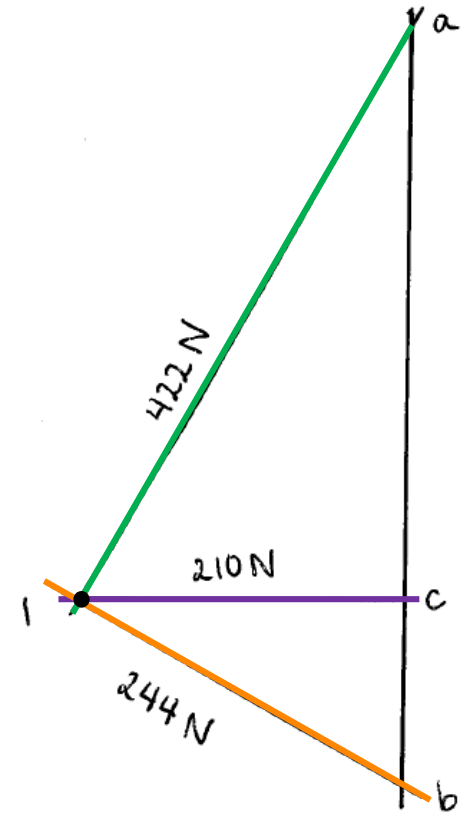
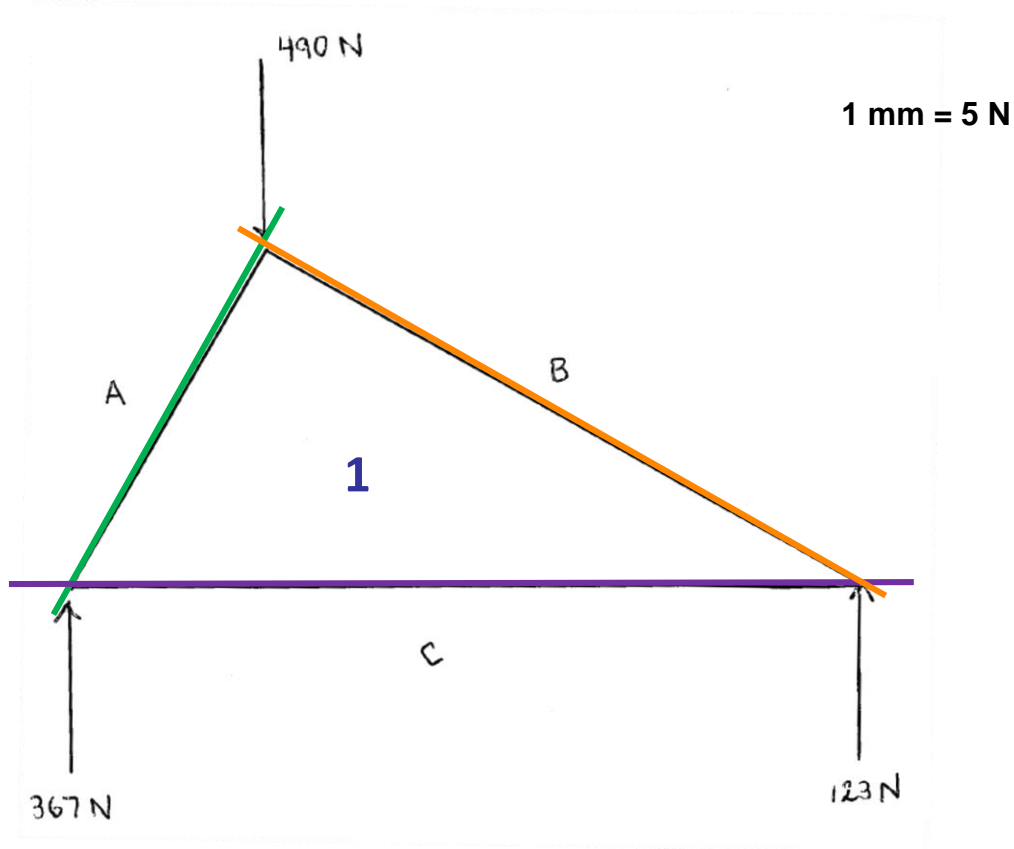

5. Finish the Force Diagram & measure member forces

Modifying the Geometry

Changing the Depth of the Truss

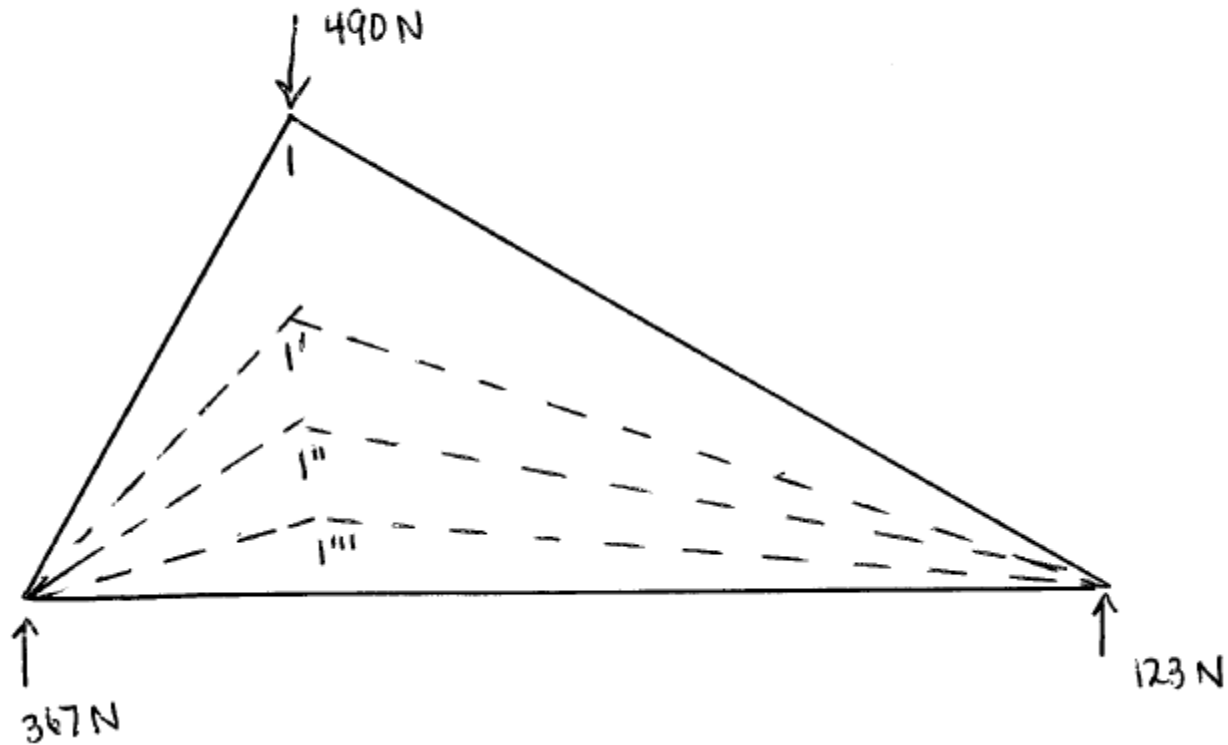

Form Diagram

Modifying the Geometry

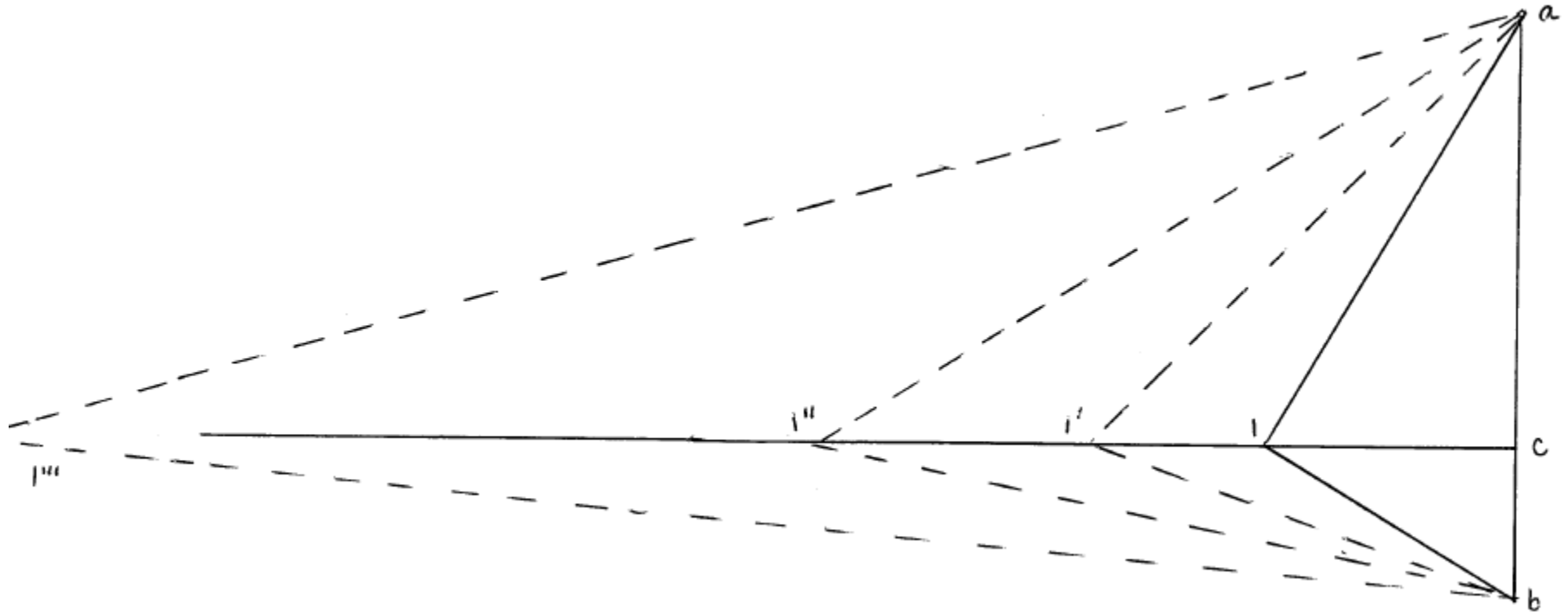

Force Diagram

Graphic Statics

What about for a more complex structure?

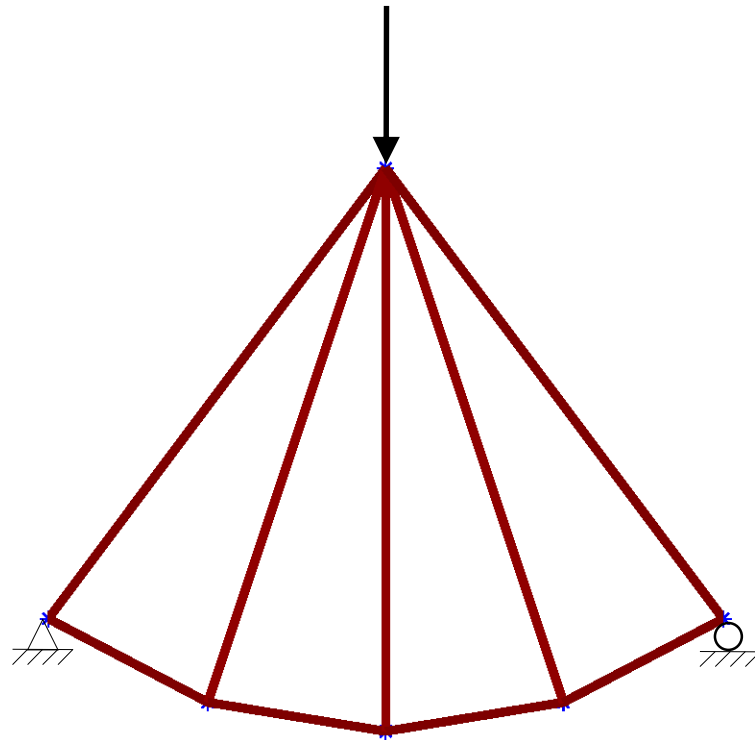

Form Diagram

Graphic Statics

Draw external forces to scale, label spaces between external forces and internal polygons:

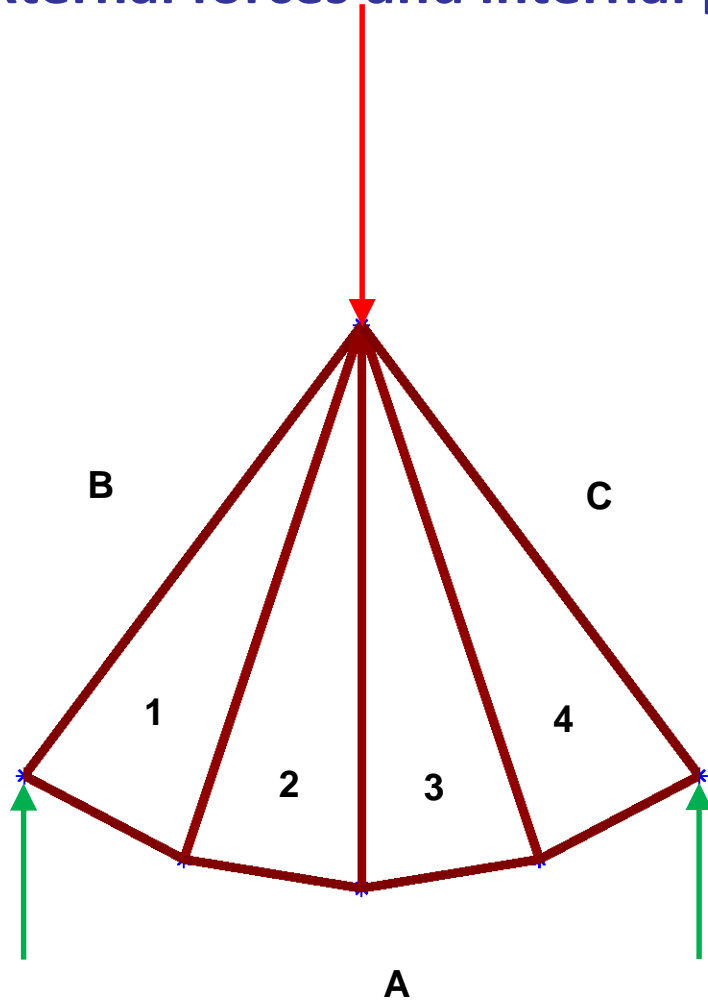

Form diagram

Force diagram



Graphic Statics

Draw line parallel to member A1:

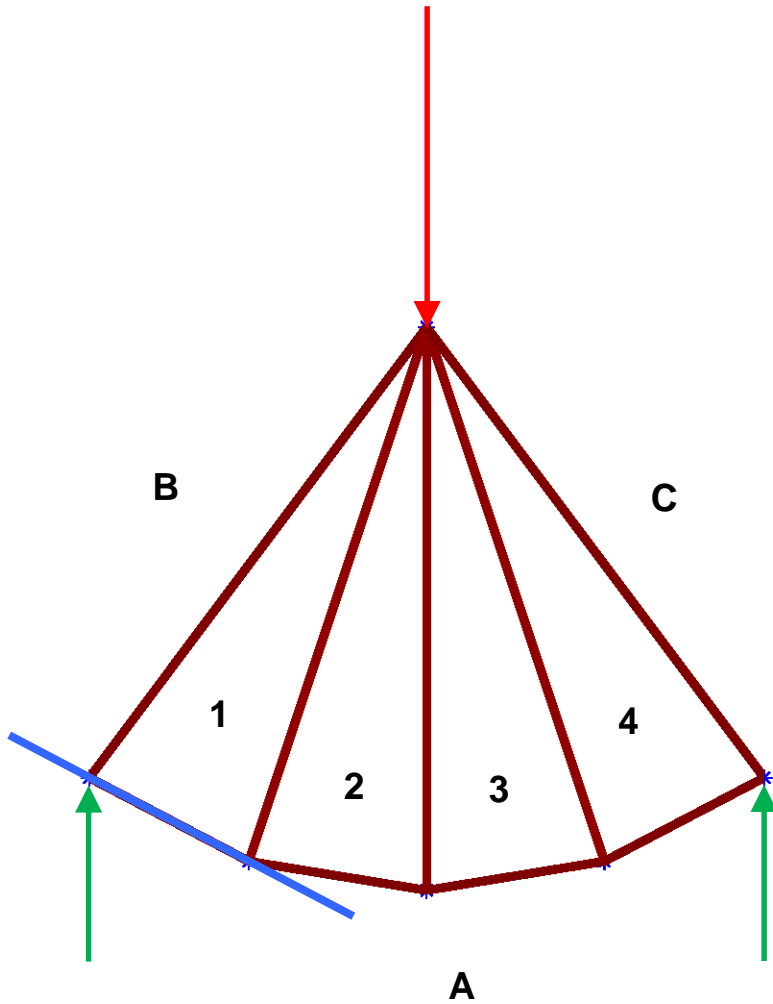

Form diagram

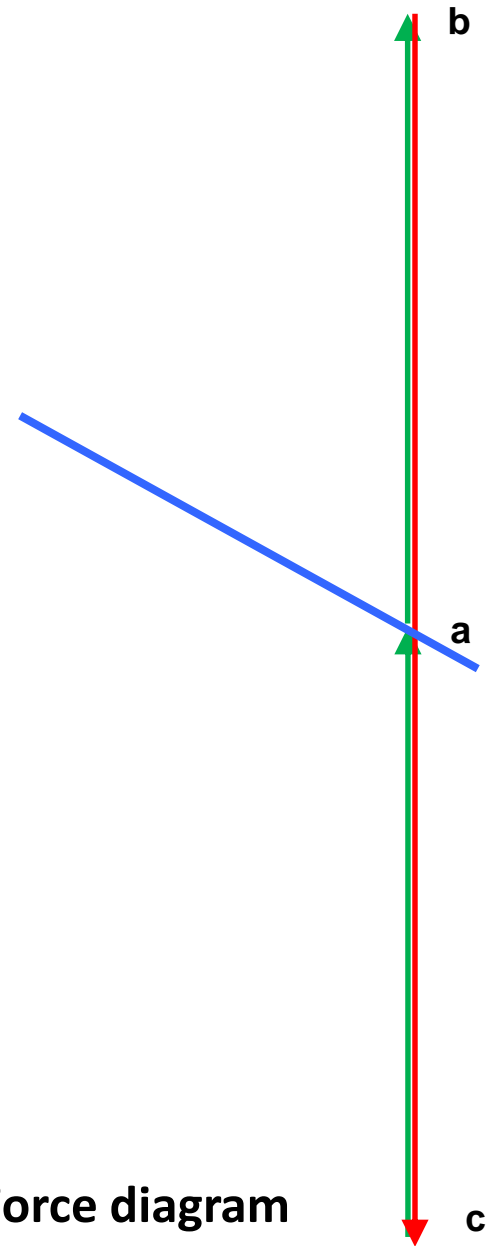

Force diagram

Graphic Statics

And line parallel to member B1:

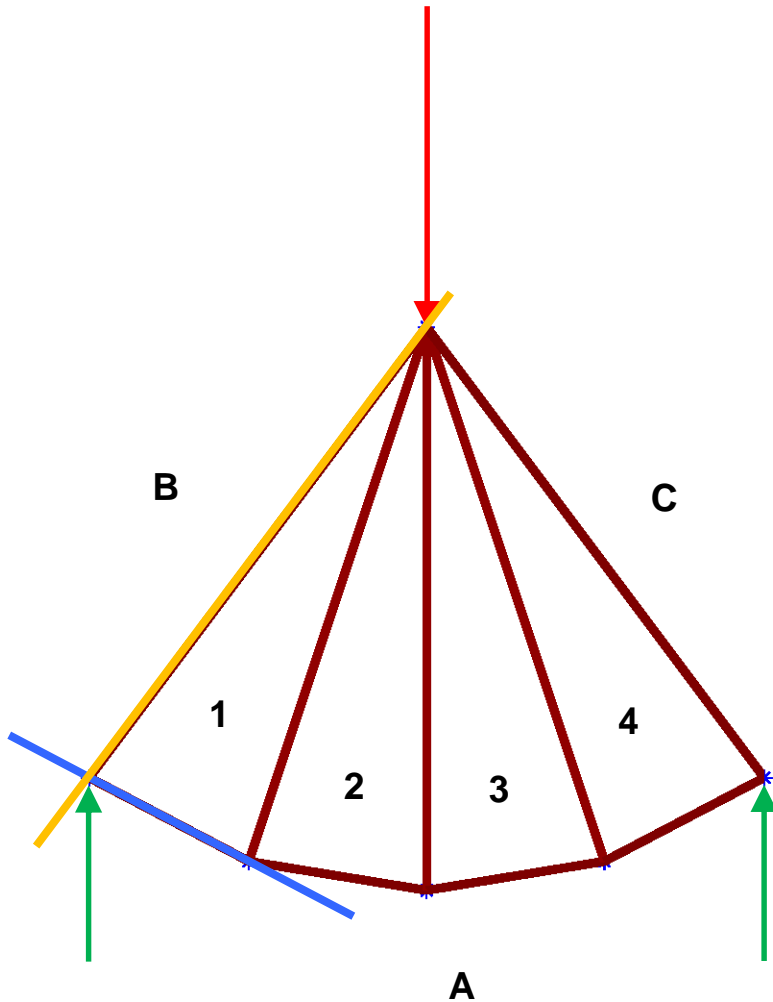

Form diagram

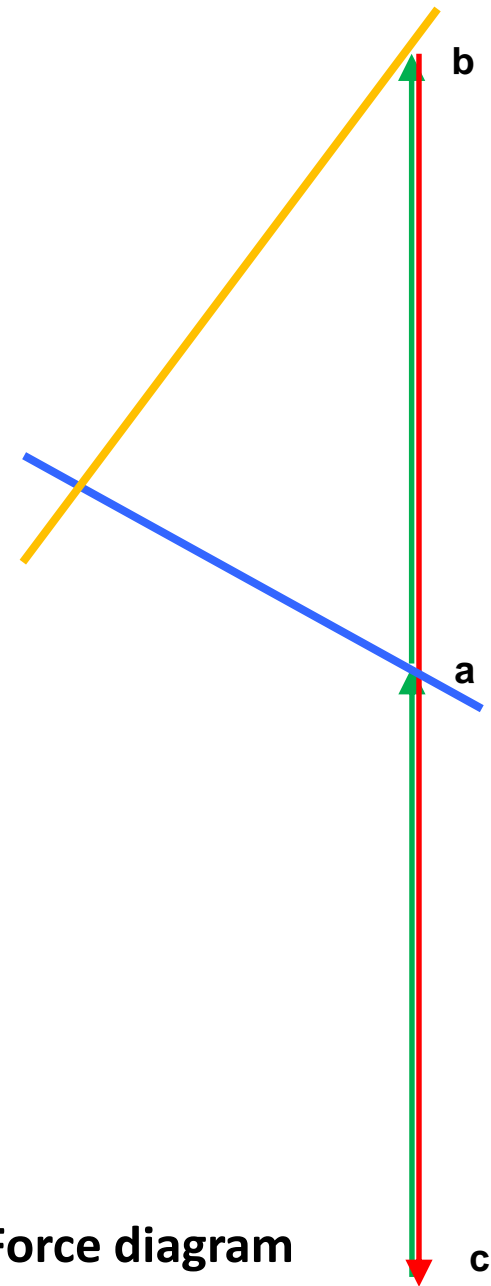

Force diagram

Graphic Statics

Label intersection Point 1:

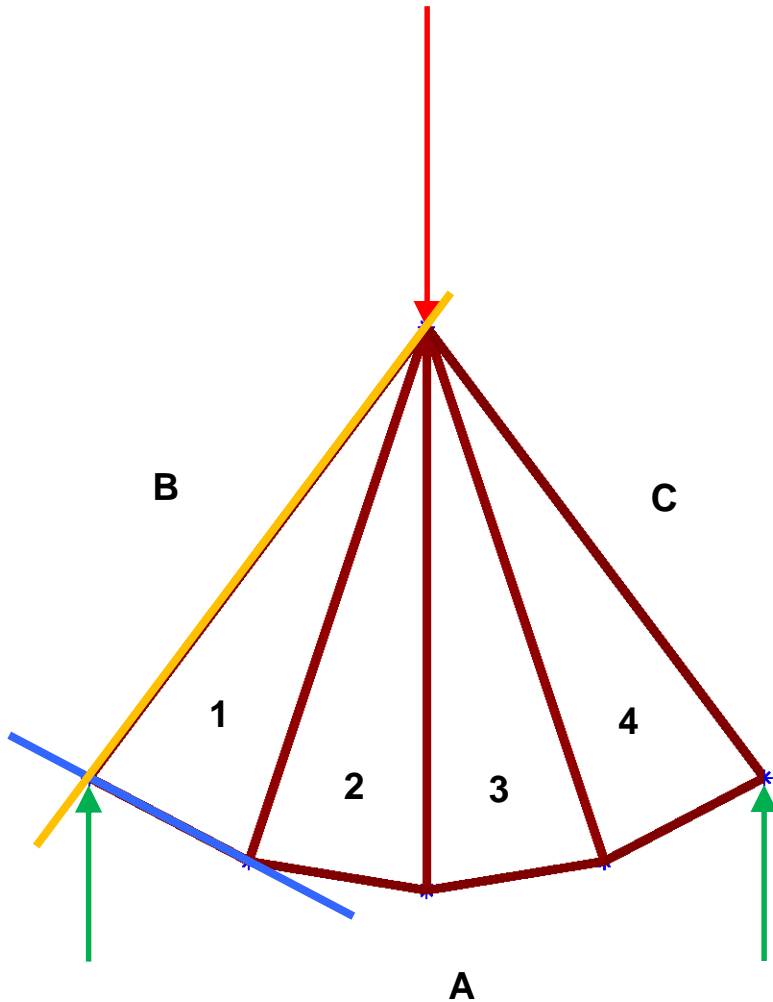

Form diagram

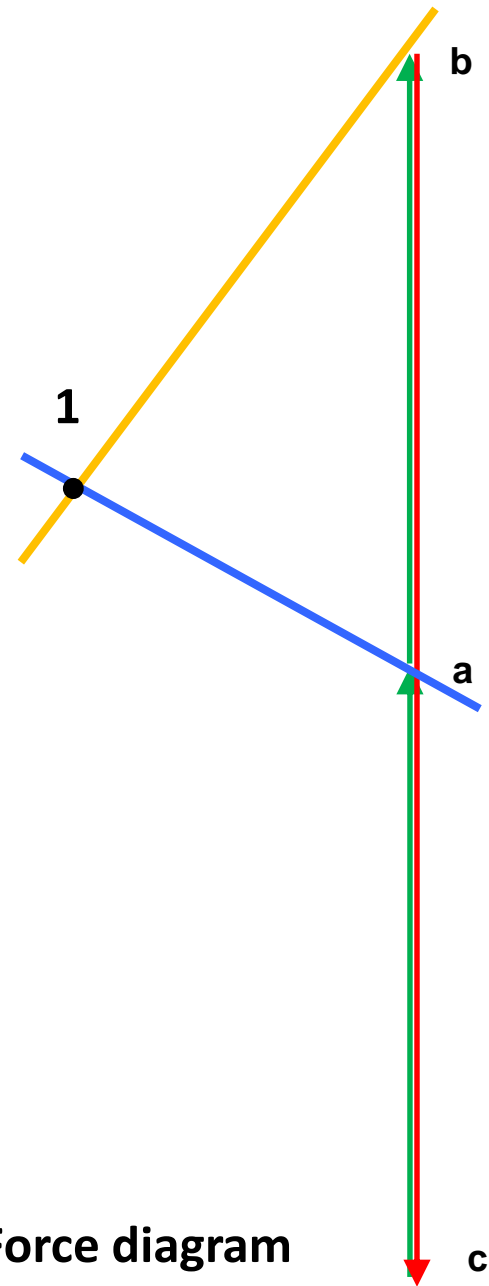

Force diagram

Graphic Statics

Continue this process to find locations of all nodes:

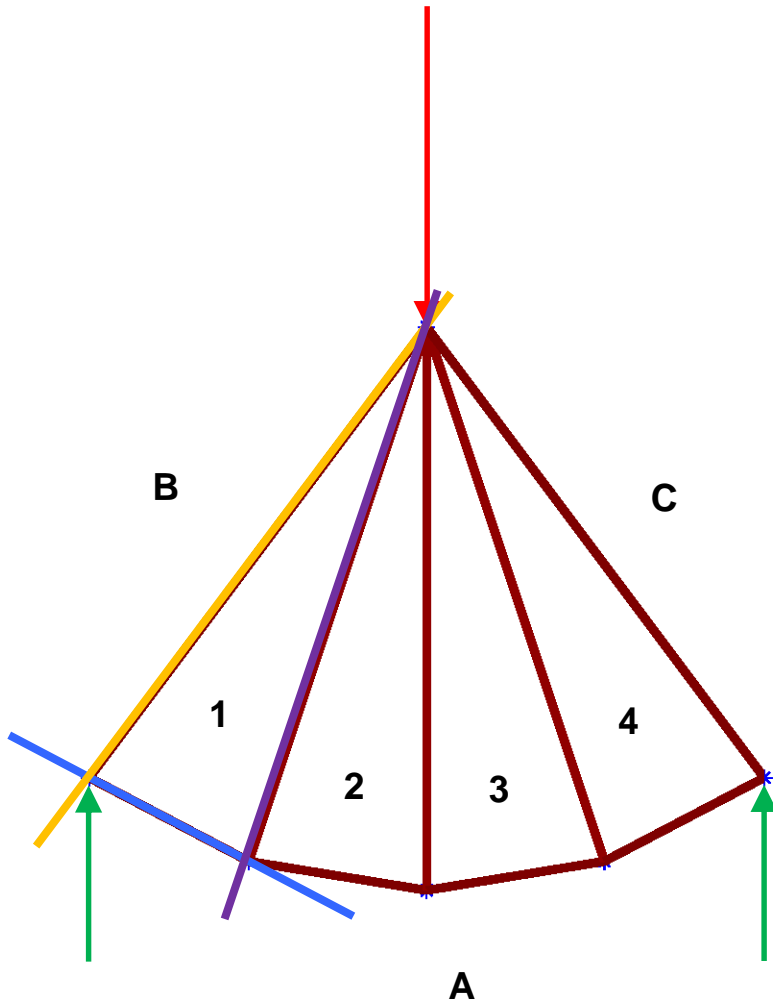

Form diagram

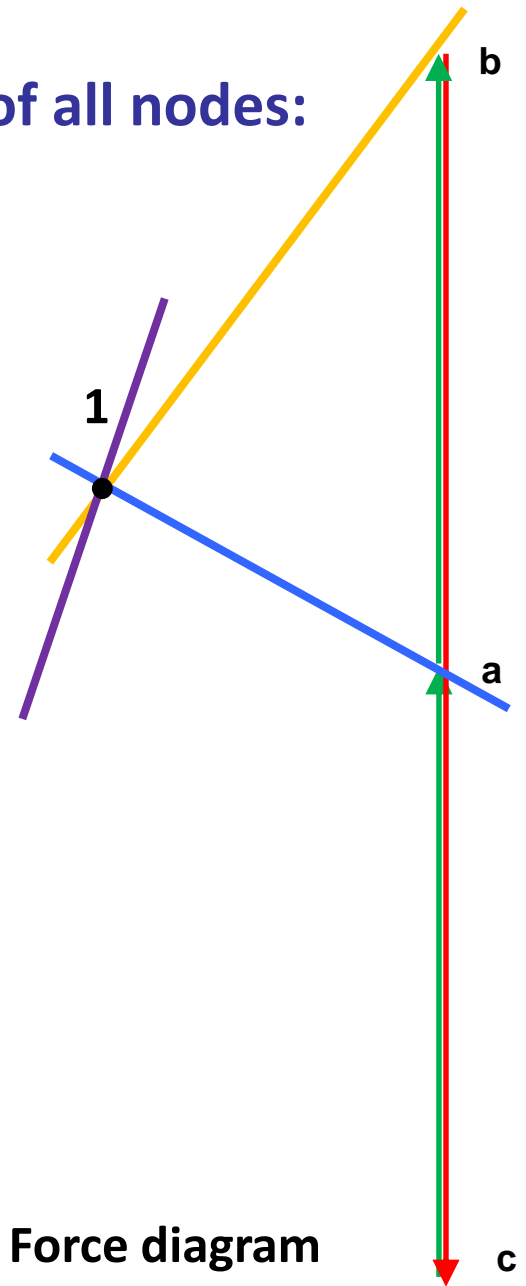

Force diagram

Graphic Statics

Continue this process to find locations of all nodes:

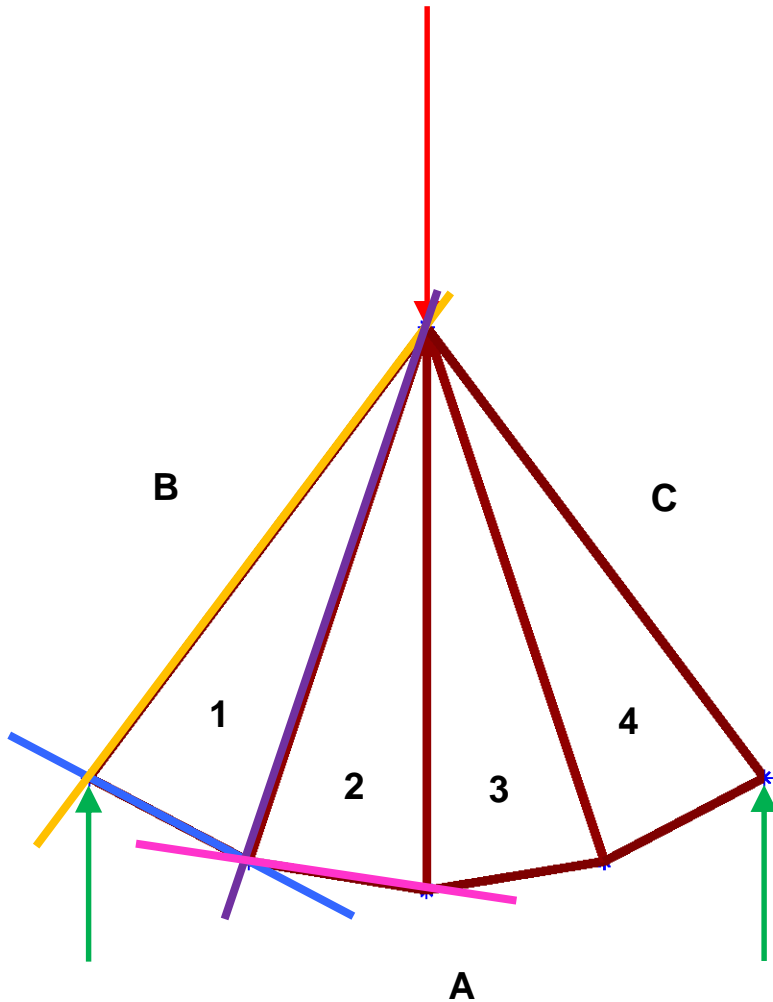

Form diagram

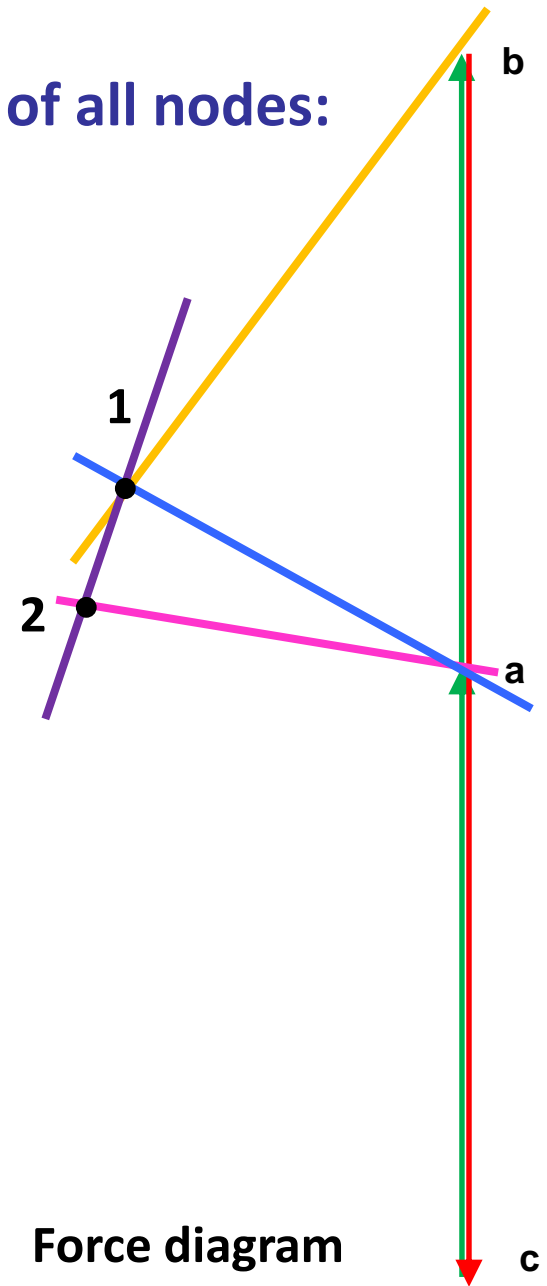

Force diagram

Graphic Statics

Continue this process to find locations of all nodes:

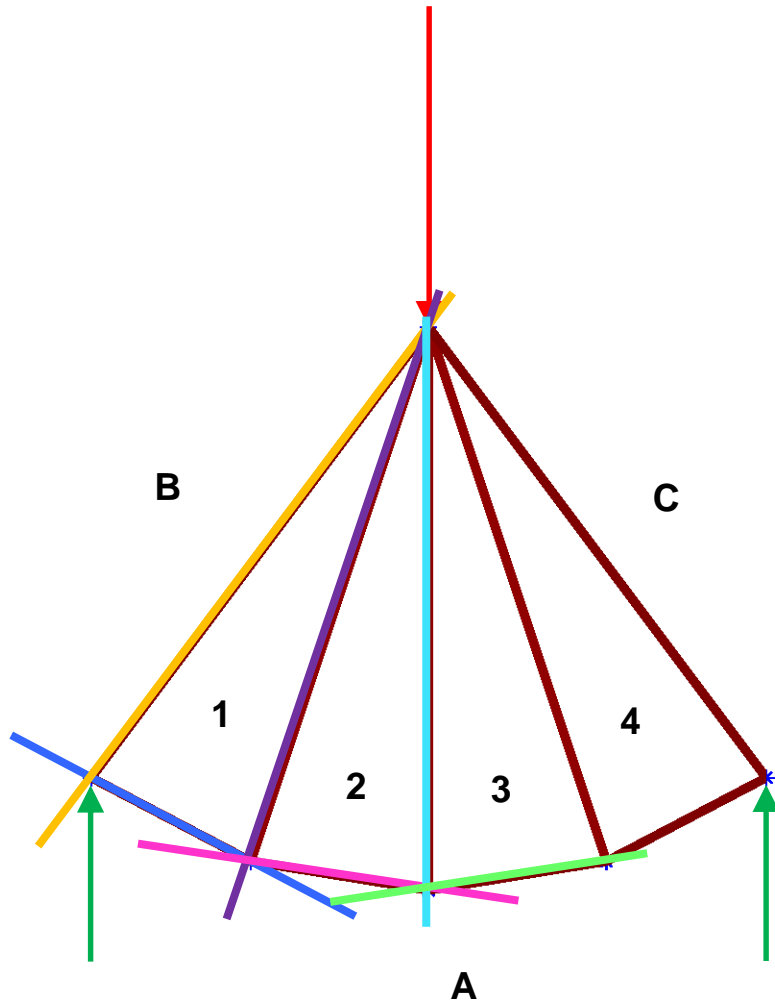

Form diagram

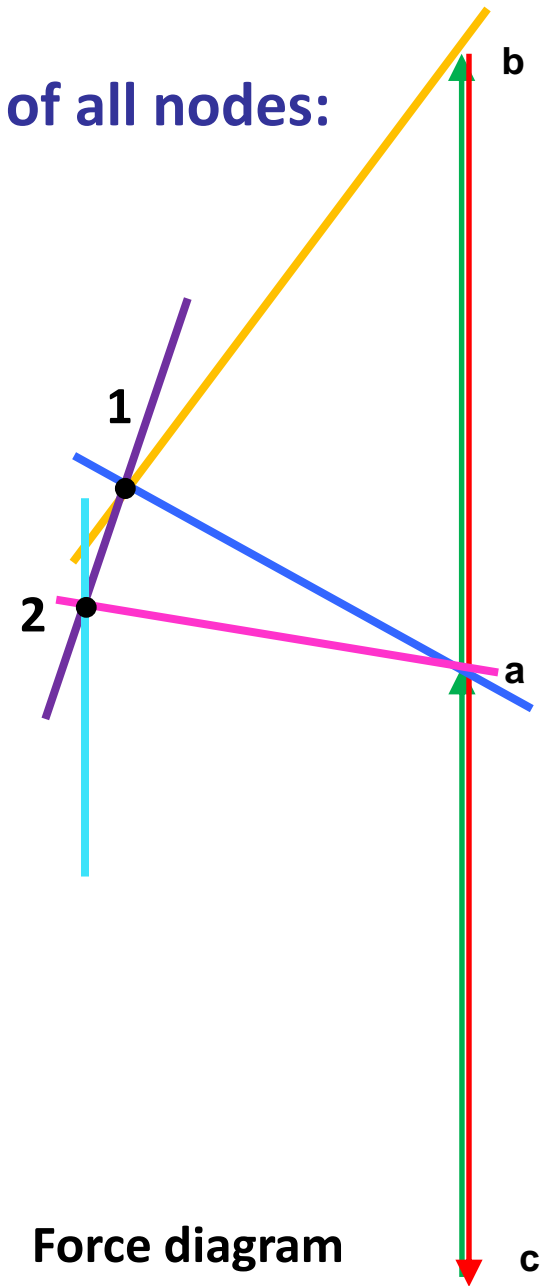

Force diagram

Graphic Statics

Continue this process to find locations of all nodes:

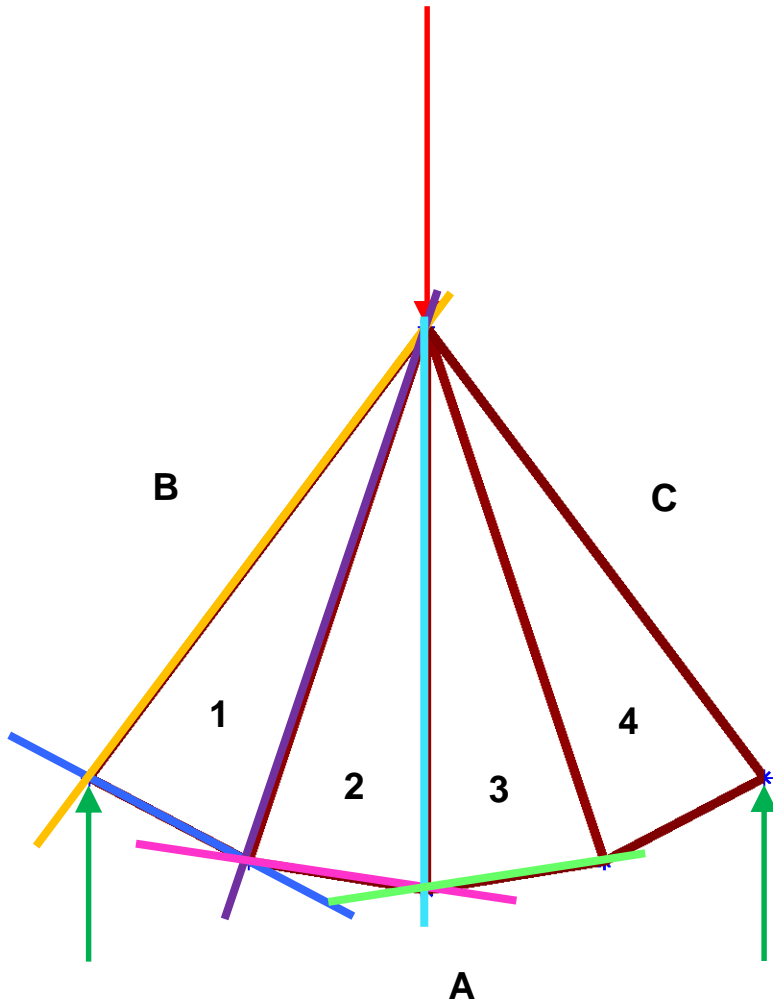

Form diagram

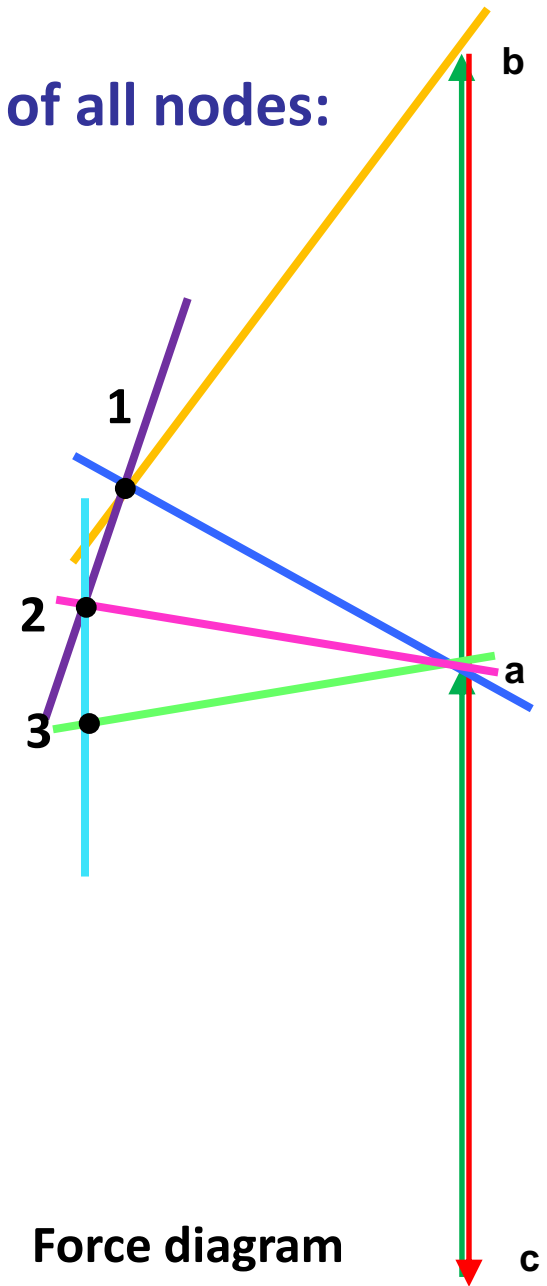

Force diagram

Graphic Statics

Continue this process to find locations of all nodes:

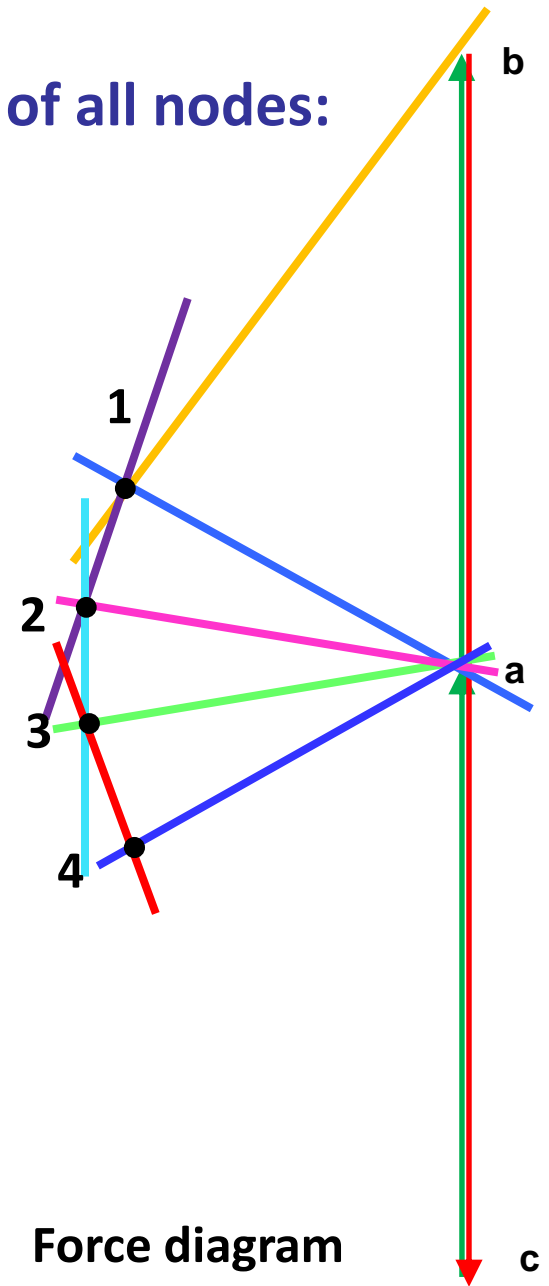
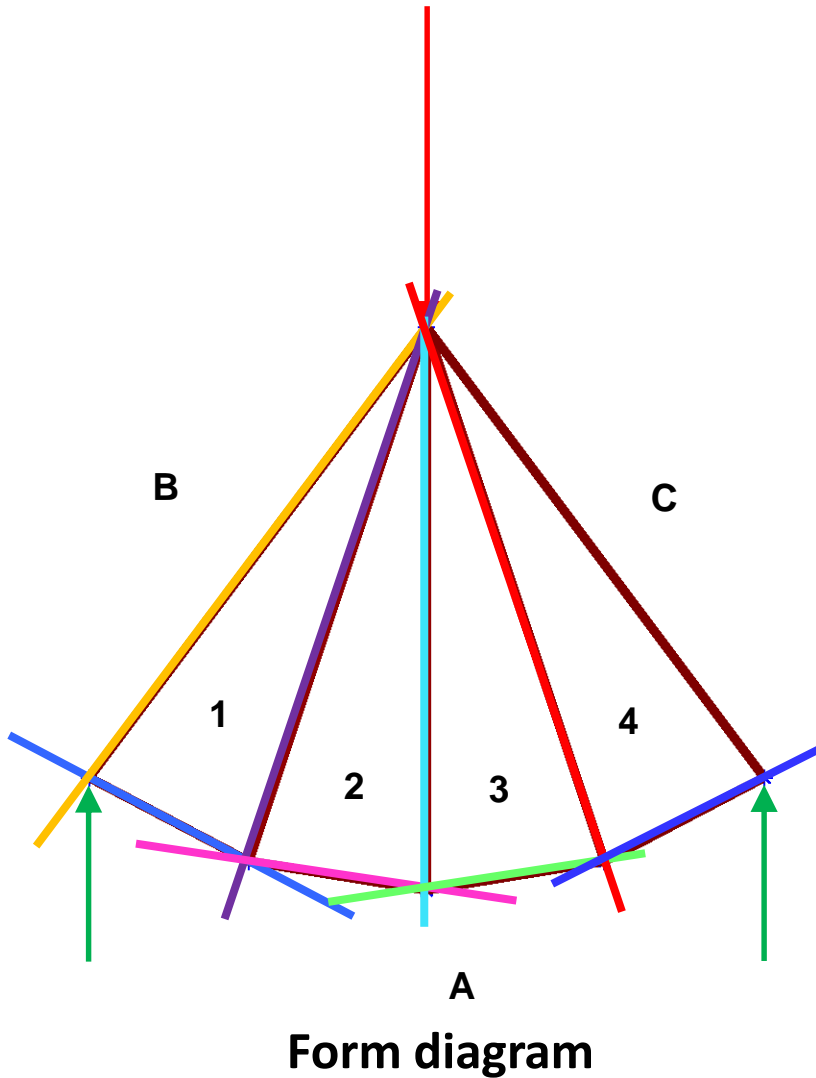

Graphic Statics

Continue this process to find locations of all nodes:

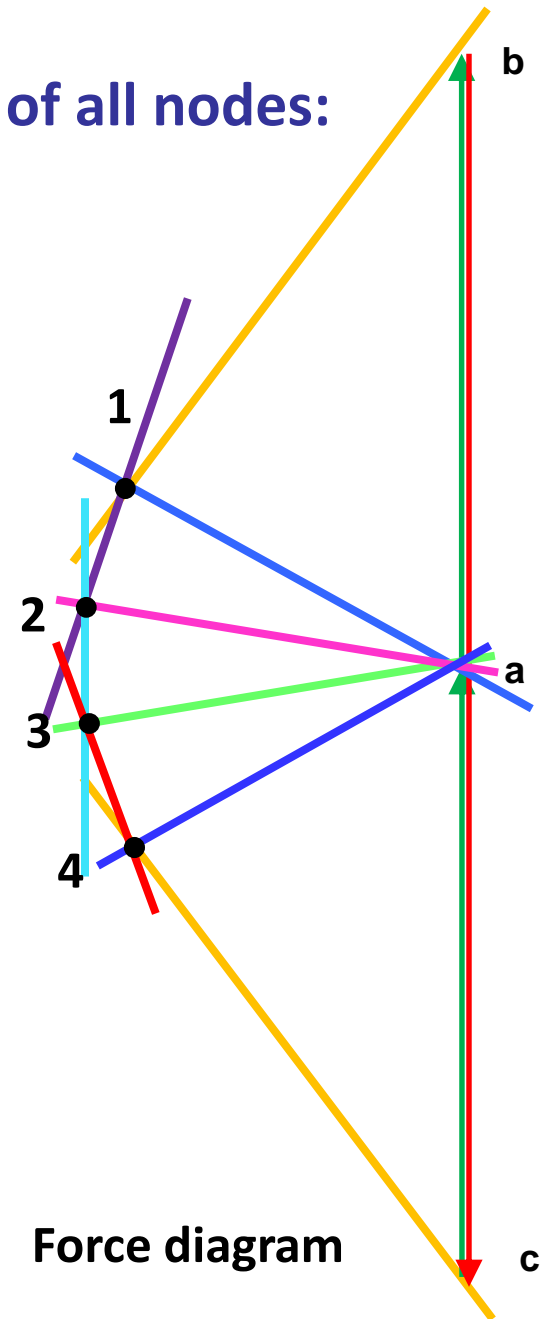
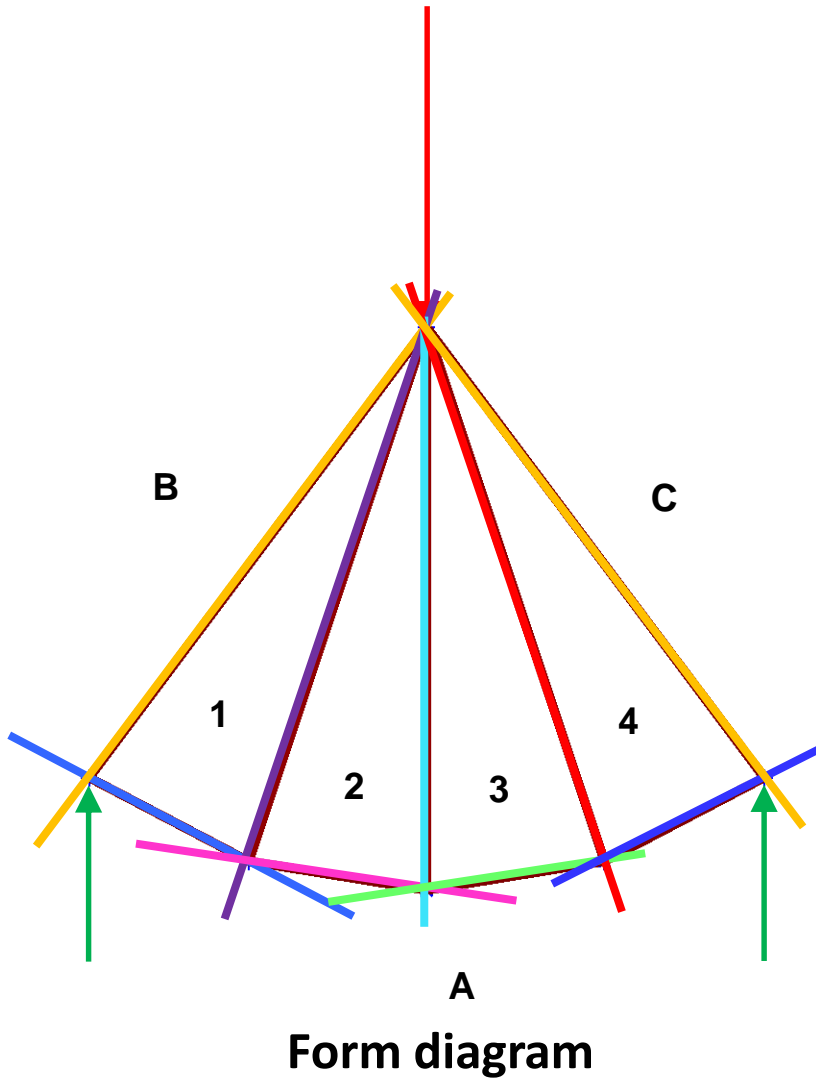

Graphic Statics

Final diagram (excluding external forces):

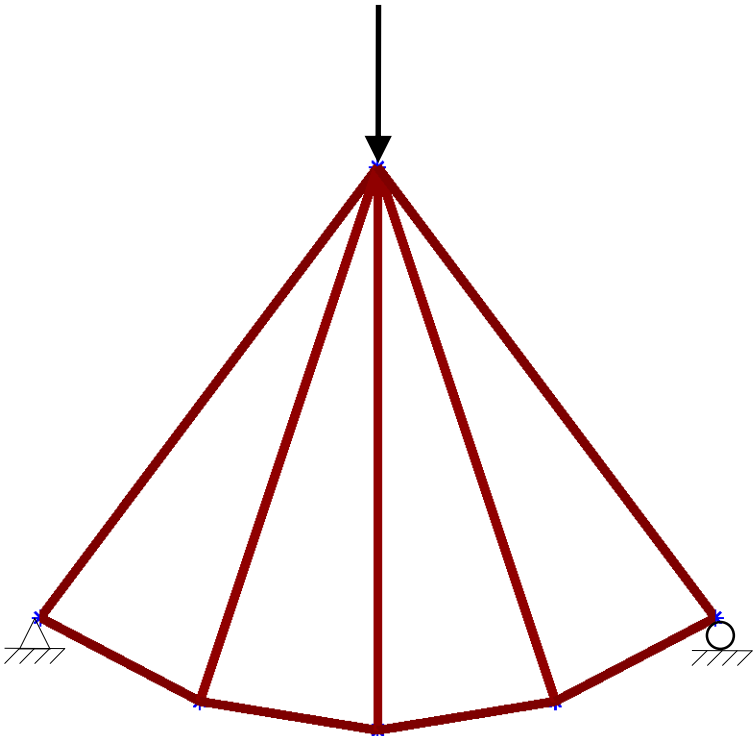

Form diagram

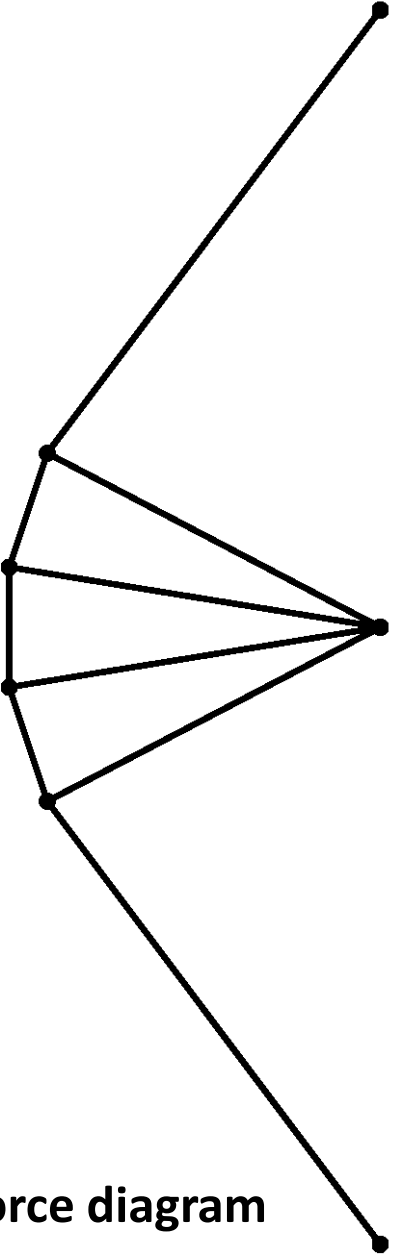

Force diagram

Graphic Statics

Other examples:

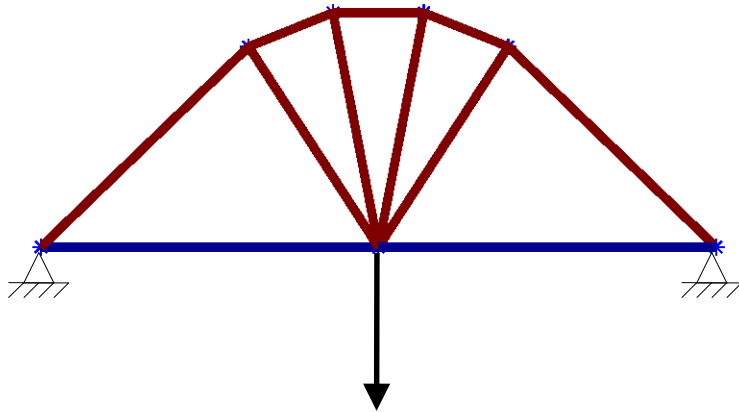

These are
reciprocal!

Form diagram

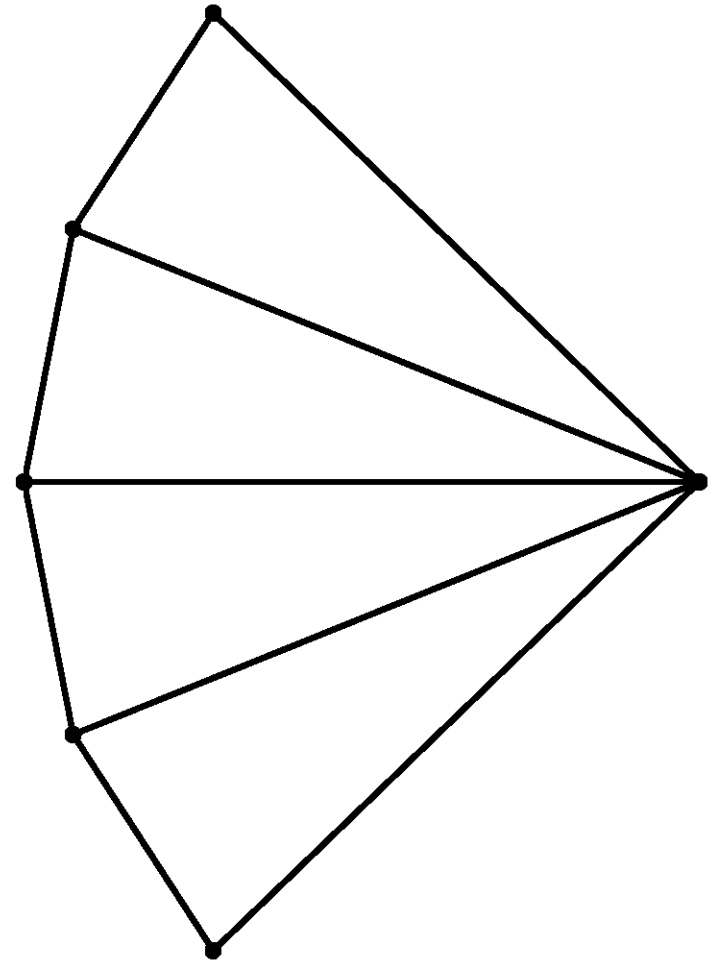

Force diagram

Graphic Statics

Reciprocal diagrams:

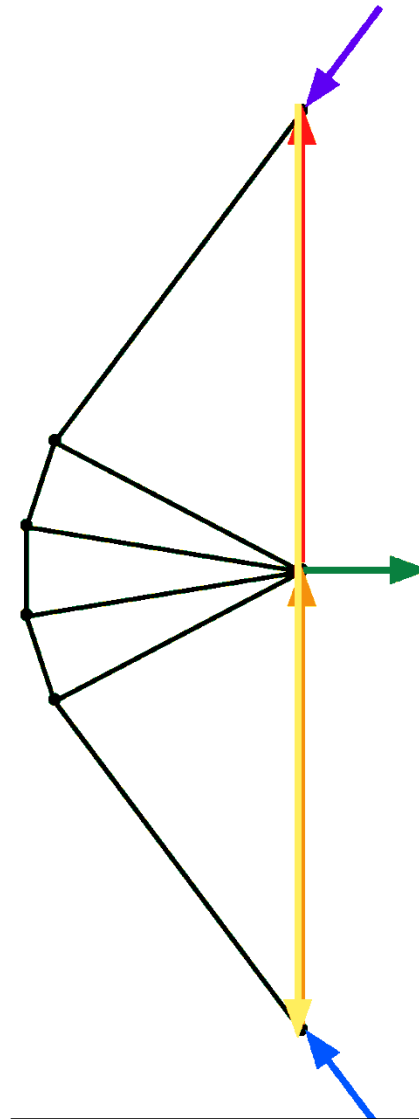
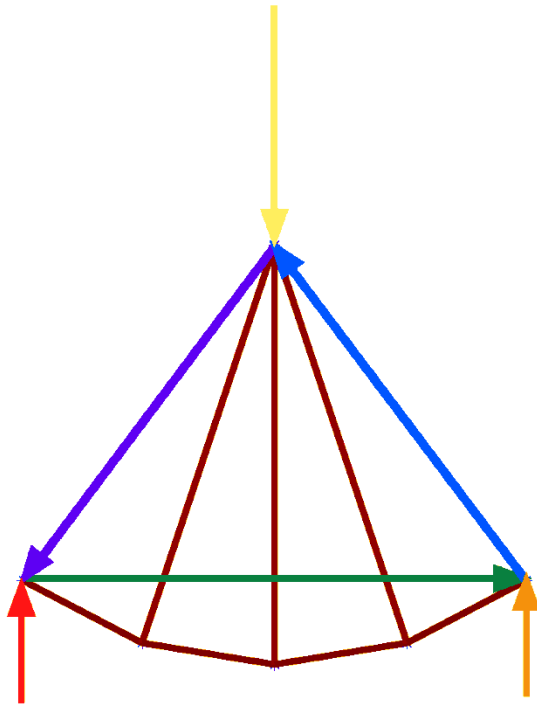

Reciprocity between loads and supports

Graphic Statics

Reciprocal diagrams:

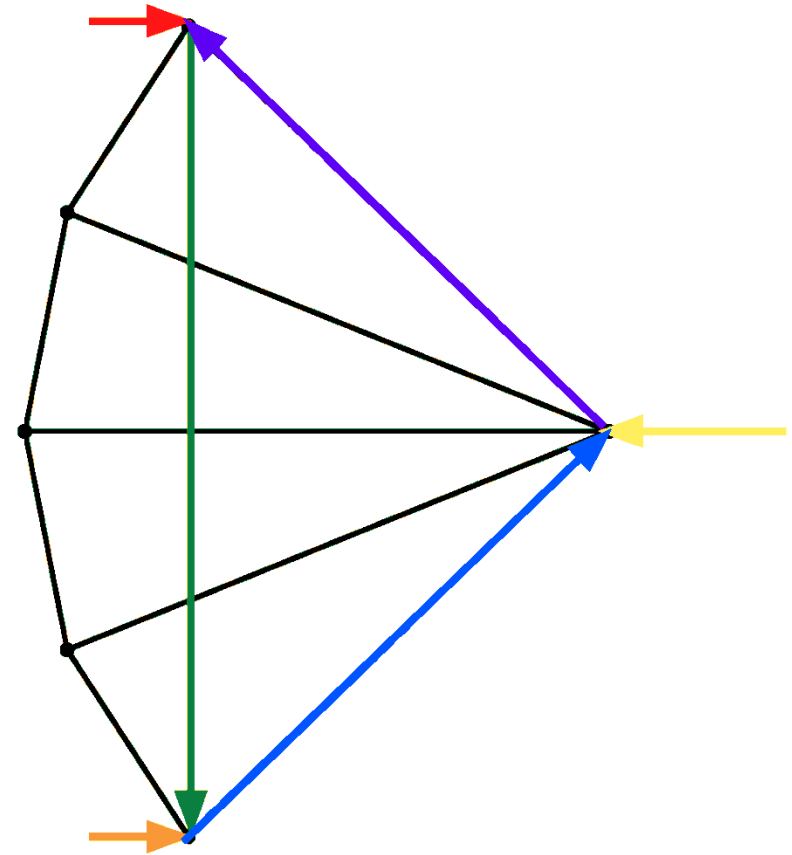
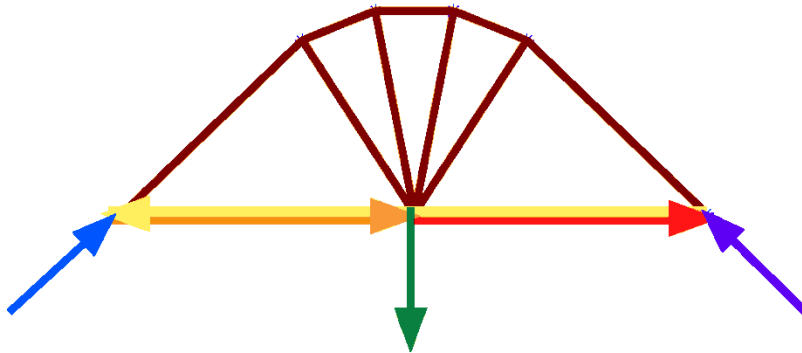

Reciprocity between loads and supports

Graphic Statics

Reciprocal diagrams:

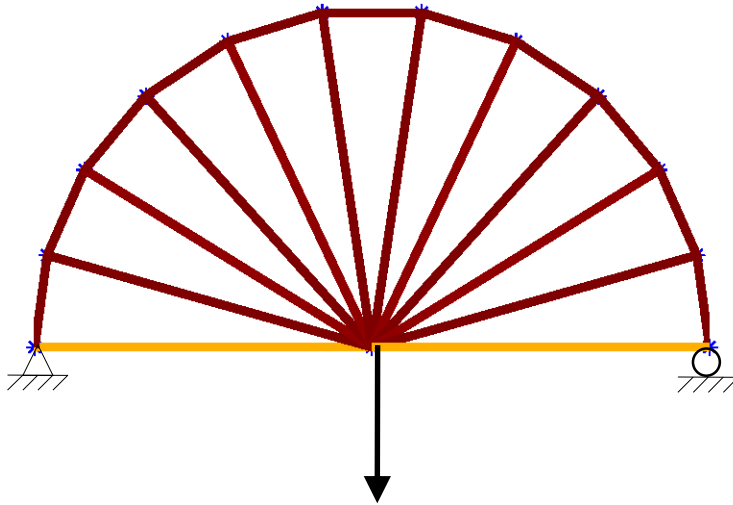

Form diagram

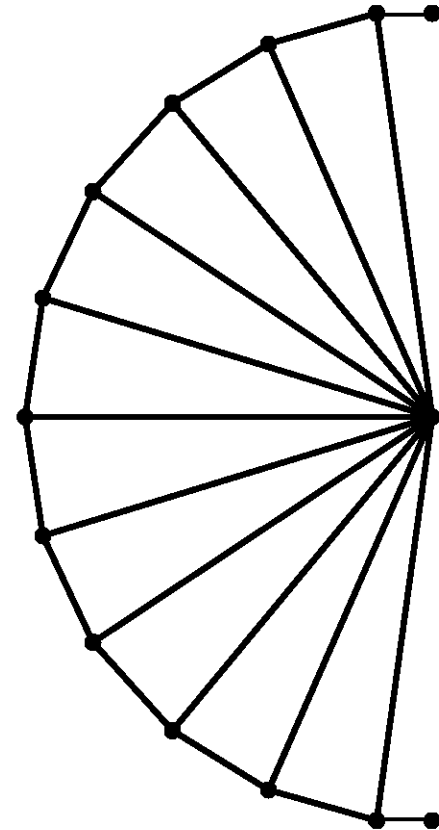

Force diagram

Graphic Statics

Why use them?

- Can optimize “unstable” structures (i.e. cables) without the need for additional members to triangulate the domain

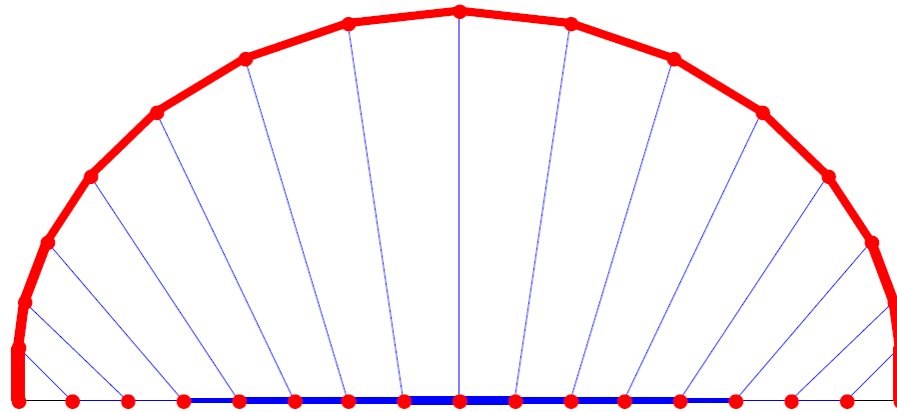

- If optimizing using the force diagram, equilibrium guaranteed for a **closed** polygon. Thus, final design is always **feasible**.

Form Finding and Optimization

How can we use the force diagram to optimize this structure for a constant force in the upper chord?

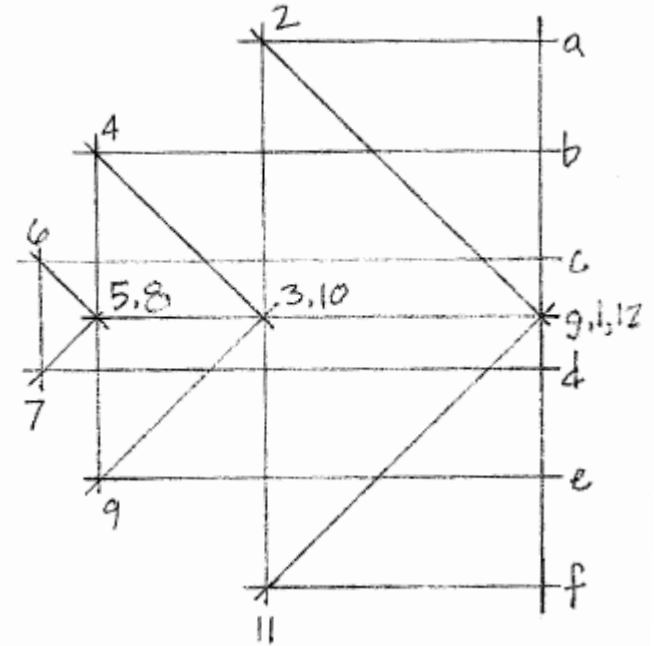
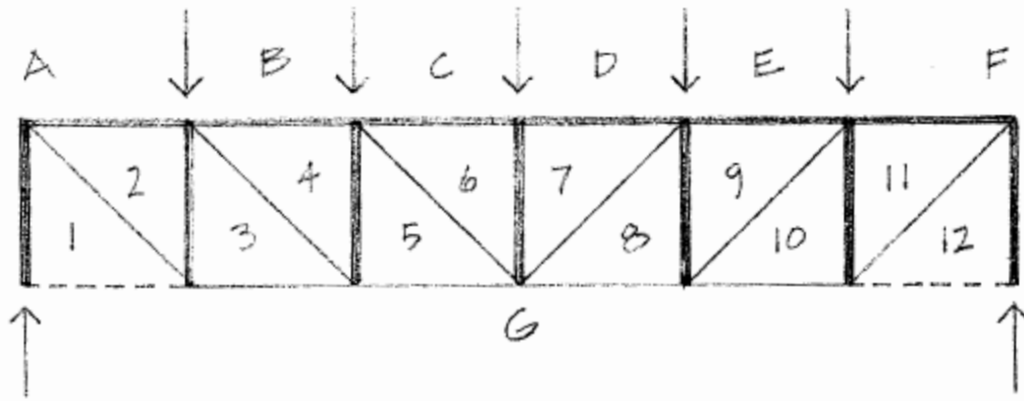

Form Finding and Optimization

How can we use the force diagram to optimize this structure for a constant force in the upper chord?

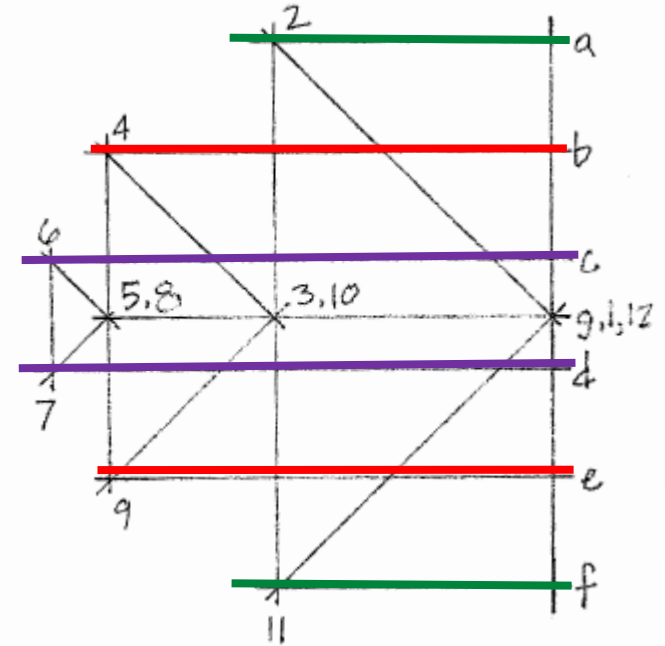
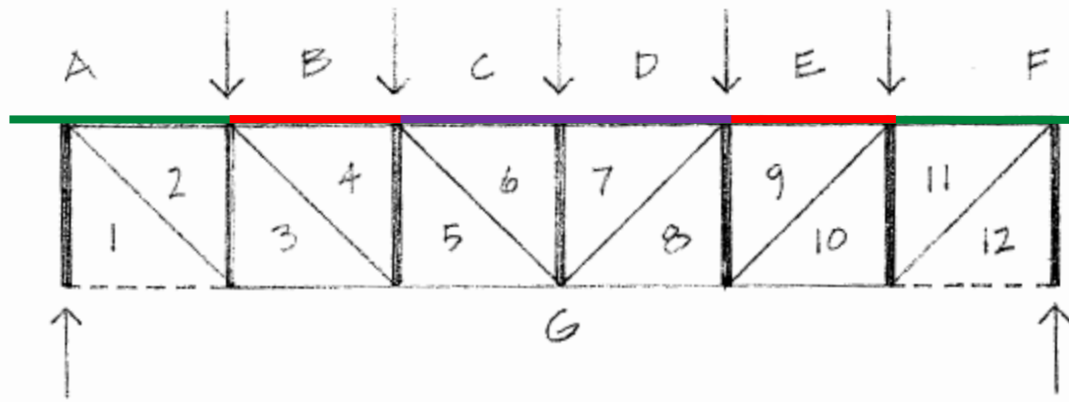

Form Finding and Optimization

How can we use the force diagram to optimize this structure for a constant force in the upper chord?

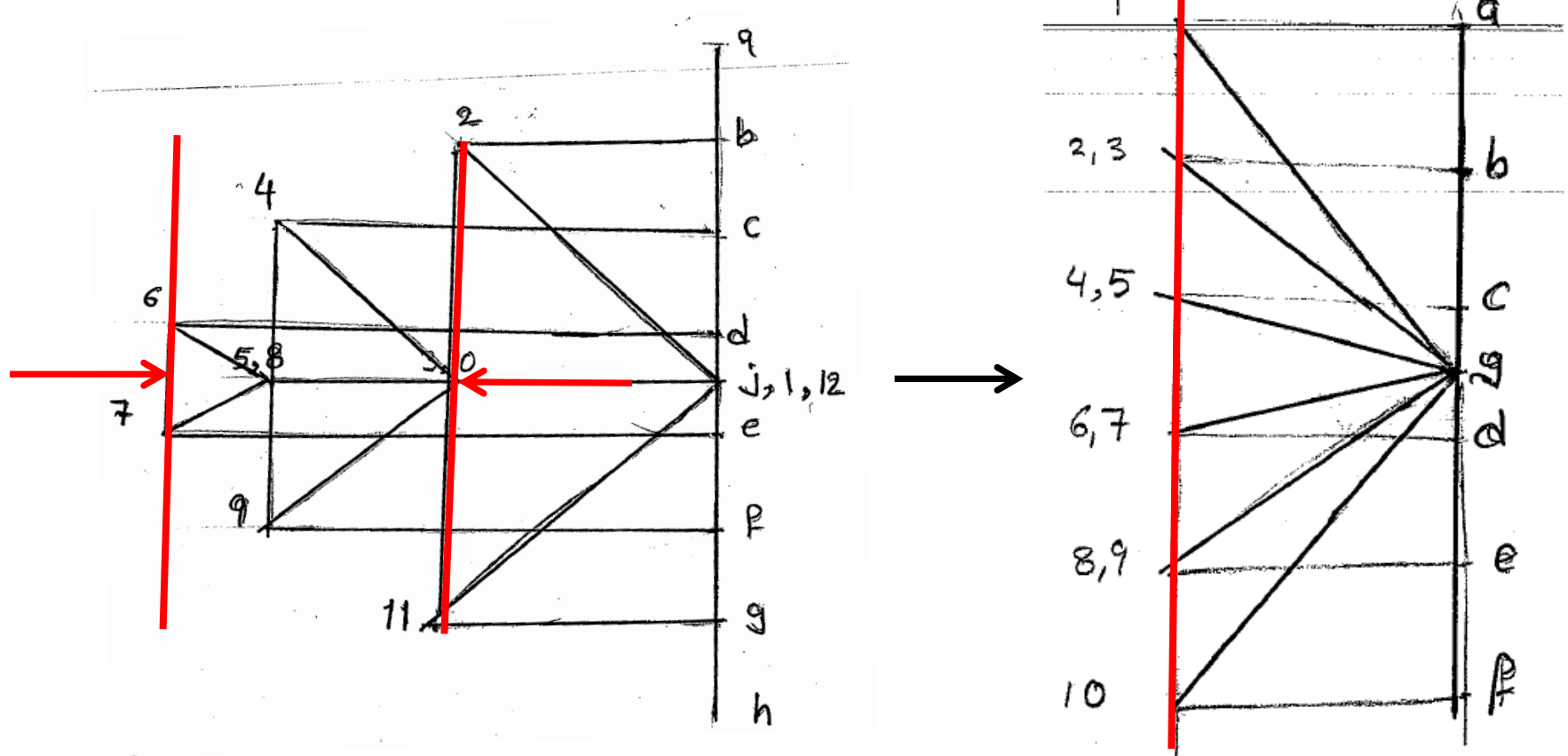

Form Finding and Optimization

Work backwards

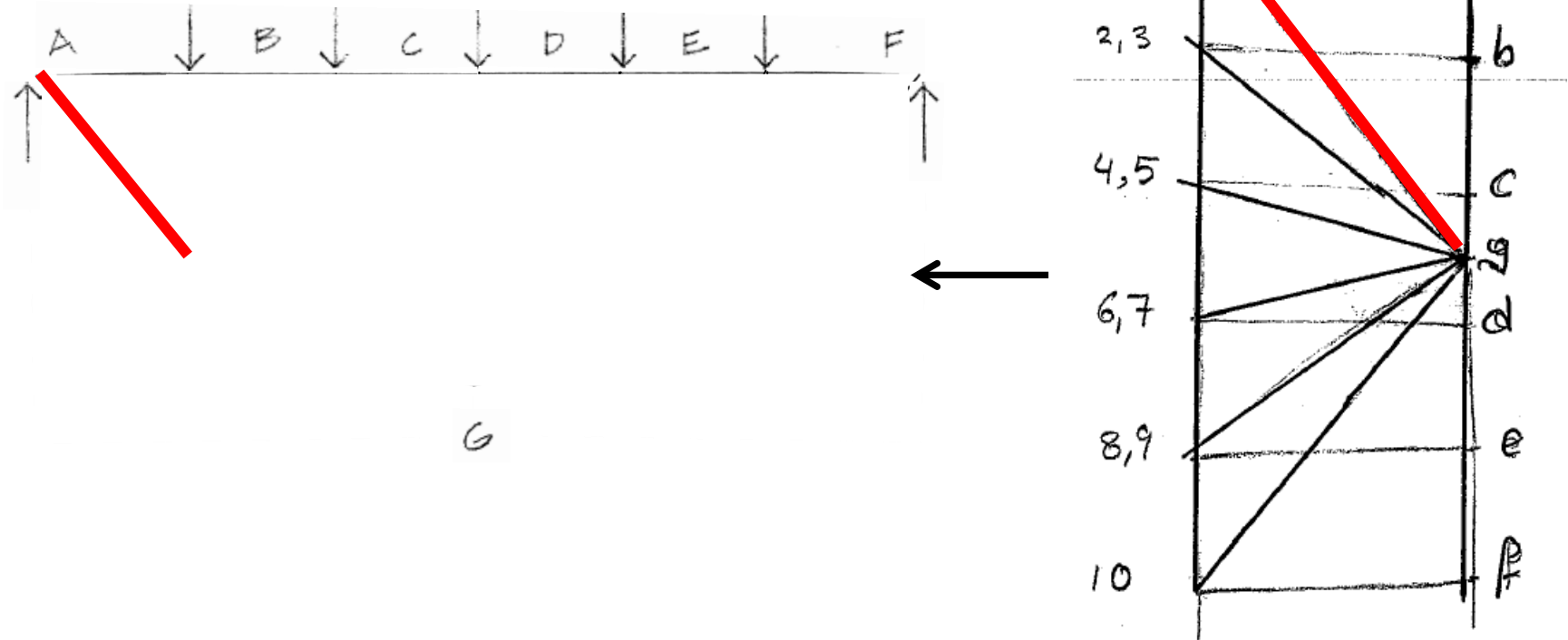

Form Finding and Optimization

Work backwards

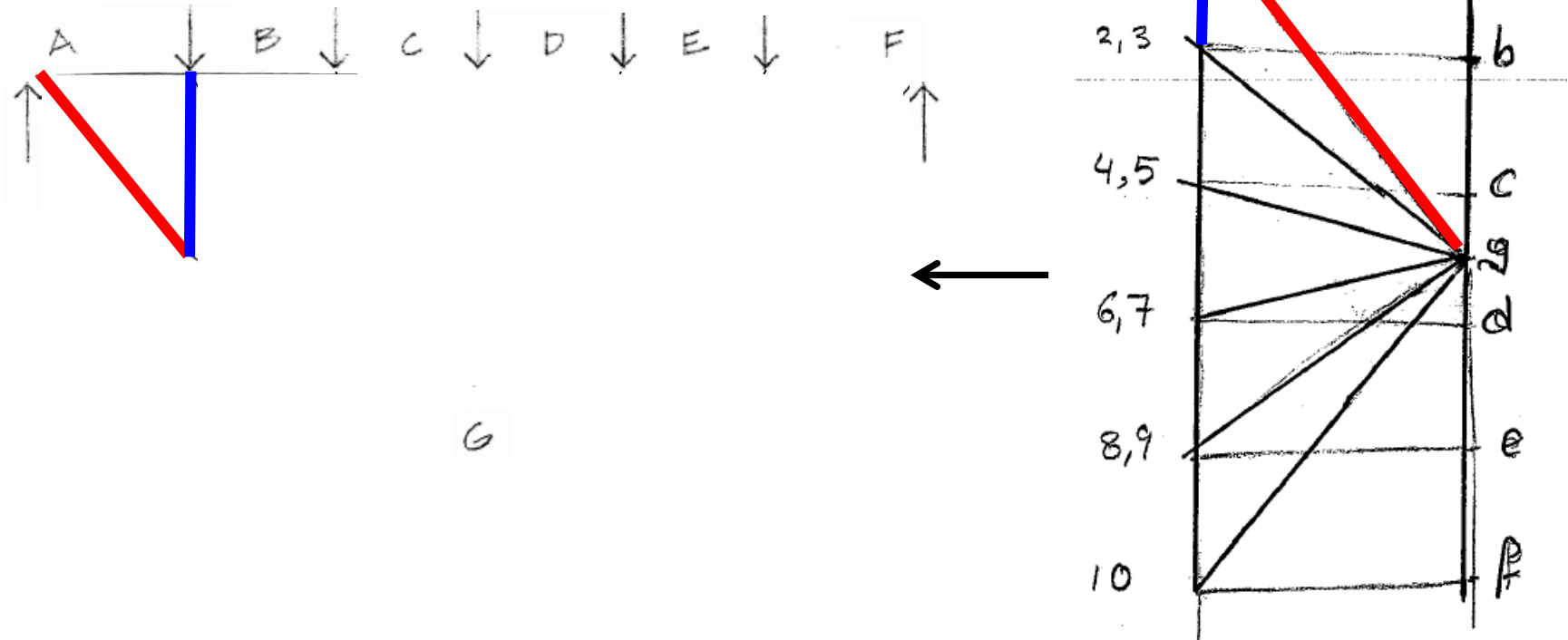

Form Finding and Optimization

Work backwards

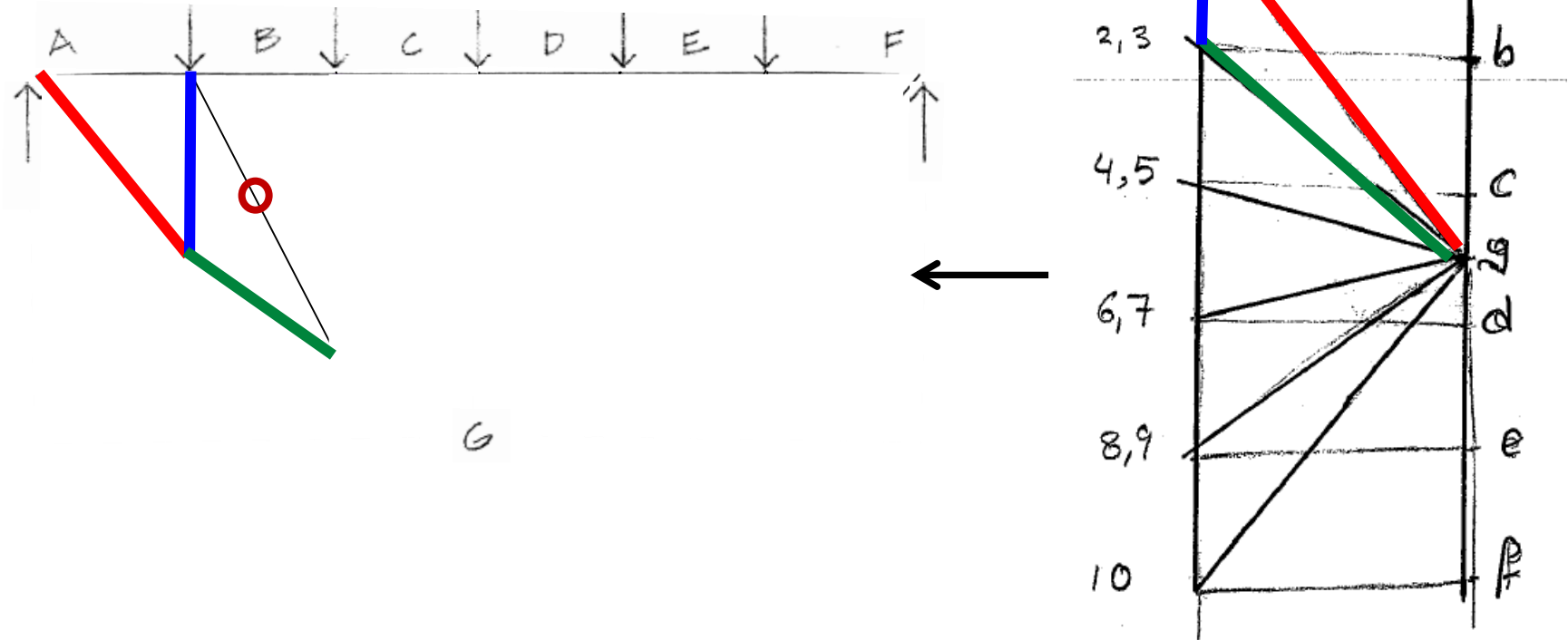

Form Finding and Optimization

Work backwards

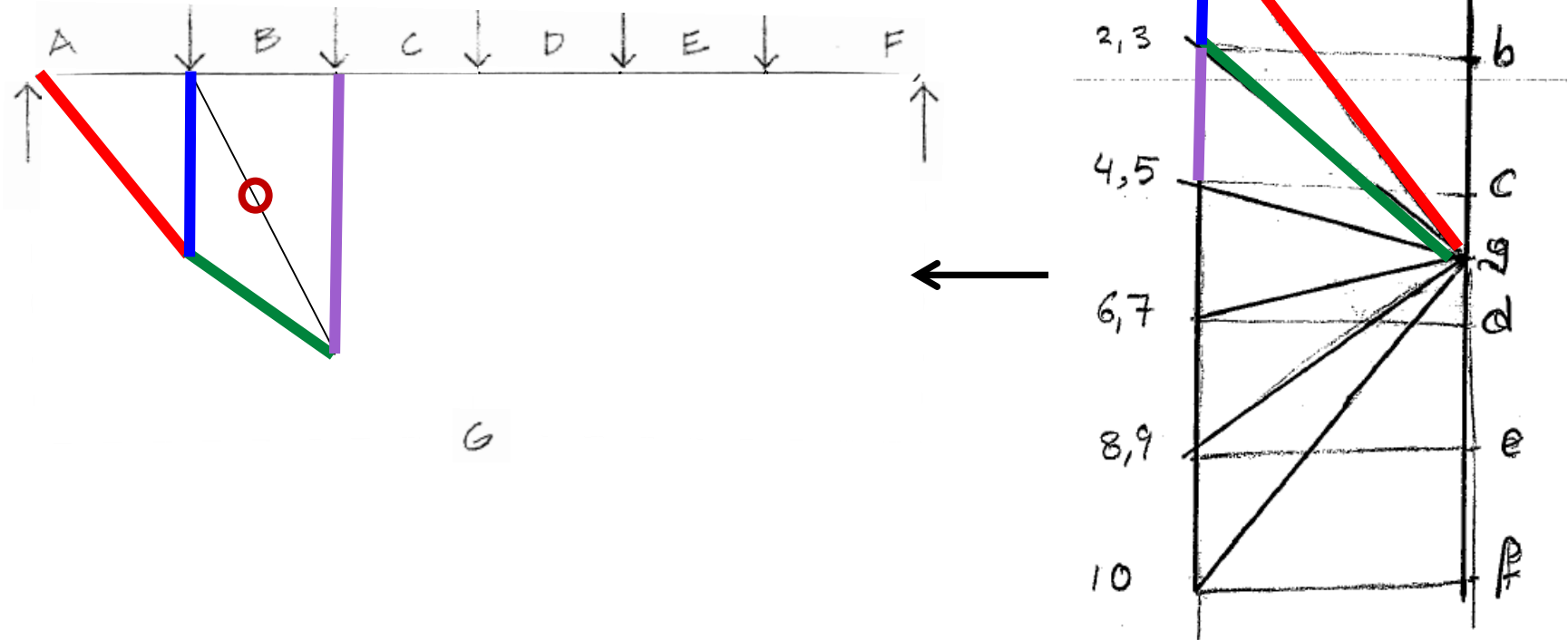

Form Finding and Optimization

Work backwards

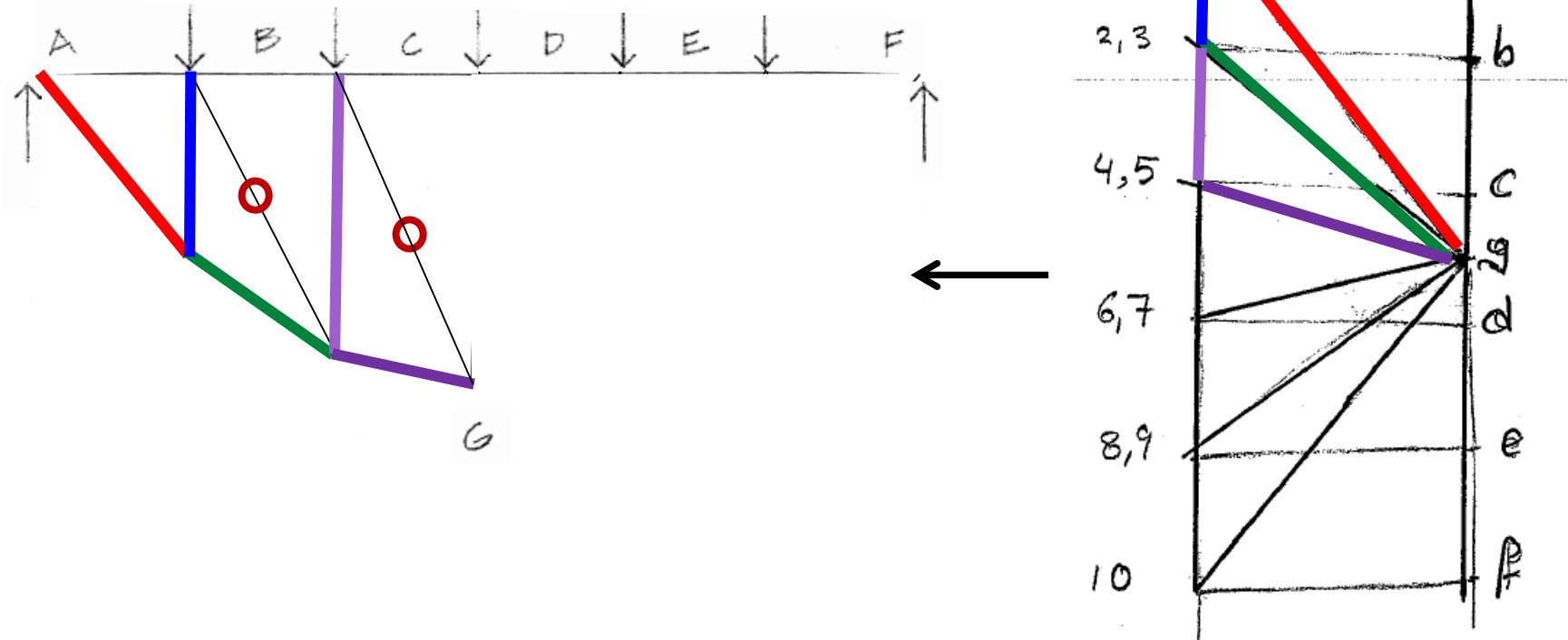

Form Finding and Optimization

Work backwards

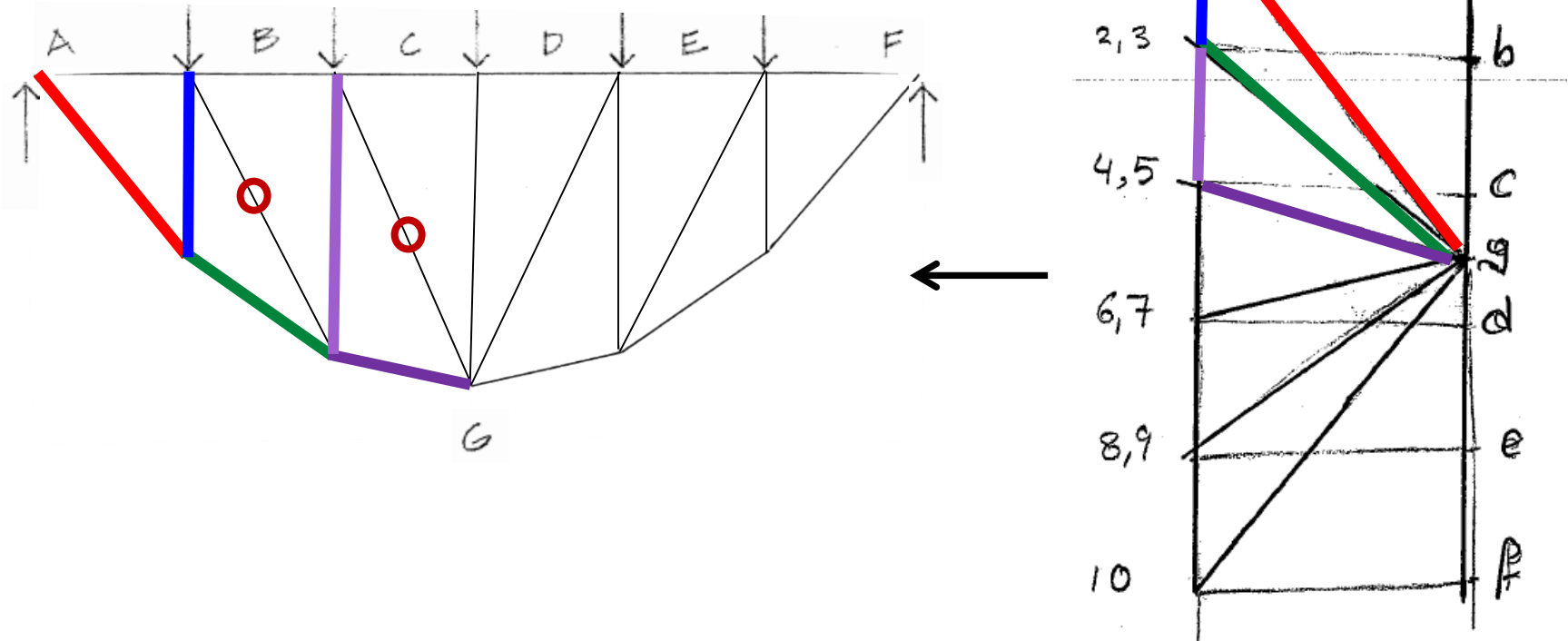

Form Finding and Optimization

Optimal upper chord

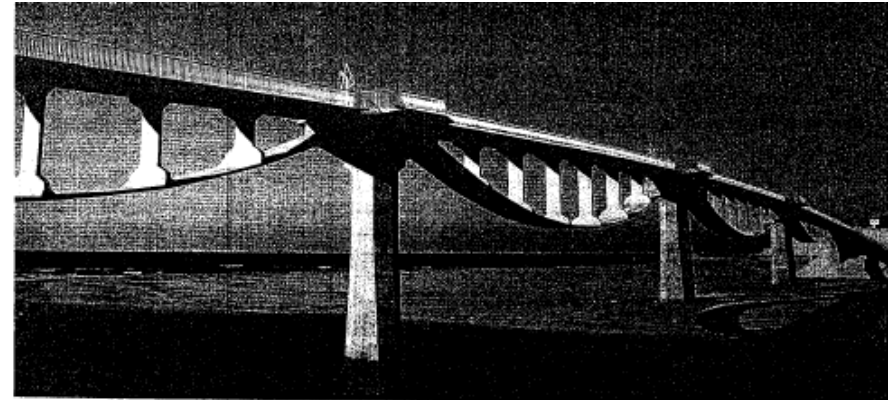
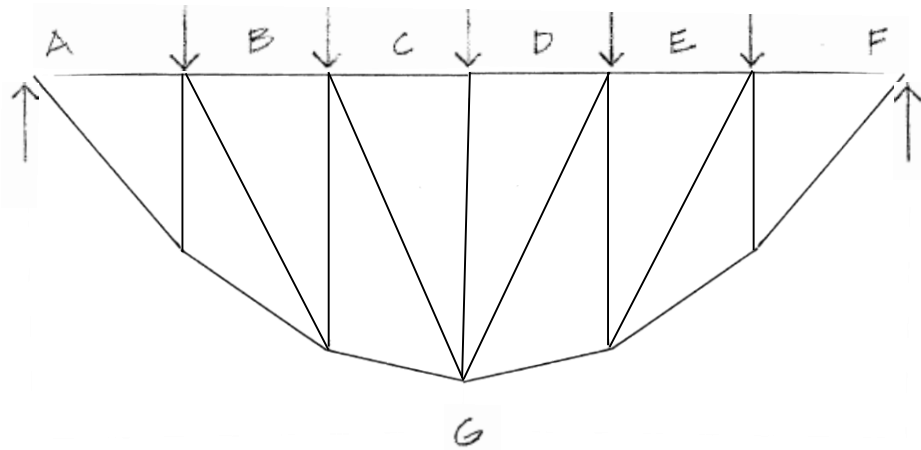

Shiosai Bridge, Japan

Form Finding and Optimization

How can we use the force diagram to optimize this structure for a constant force in the bottom chord?

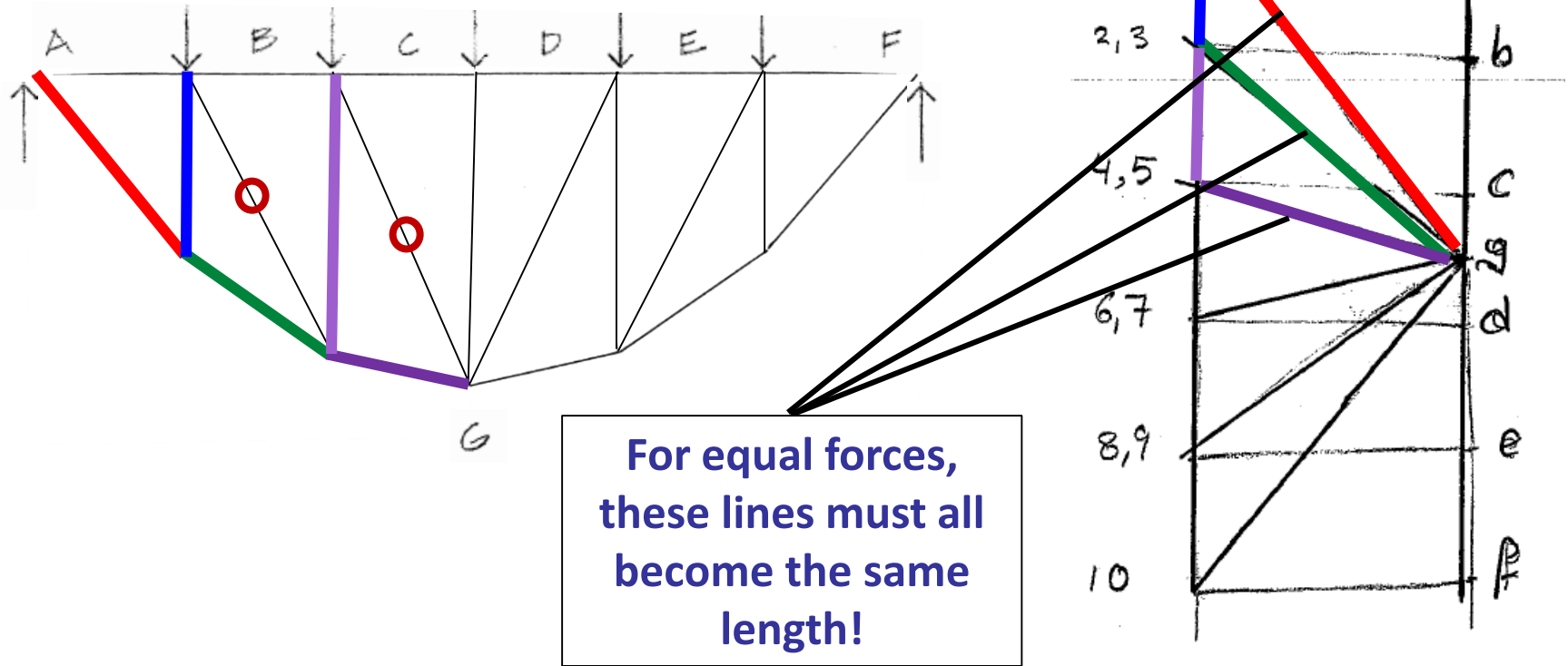

Form Finding and Optimization

How can we use the force diagram to optimize this structure for a constant force in the bottom chord?

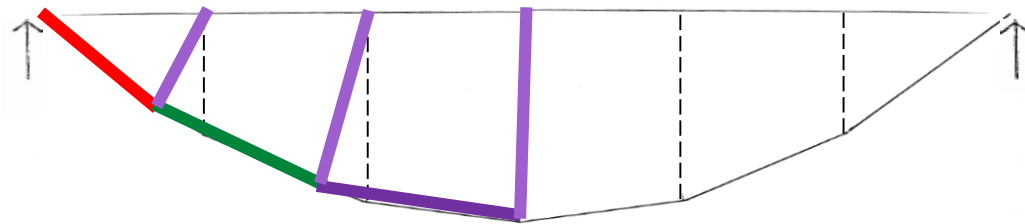

Note: This structure is “unstable” so the problem **cannot** be solved with finite element analysis!

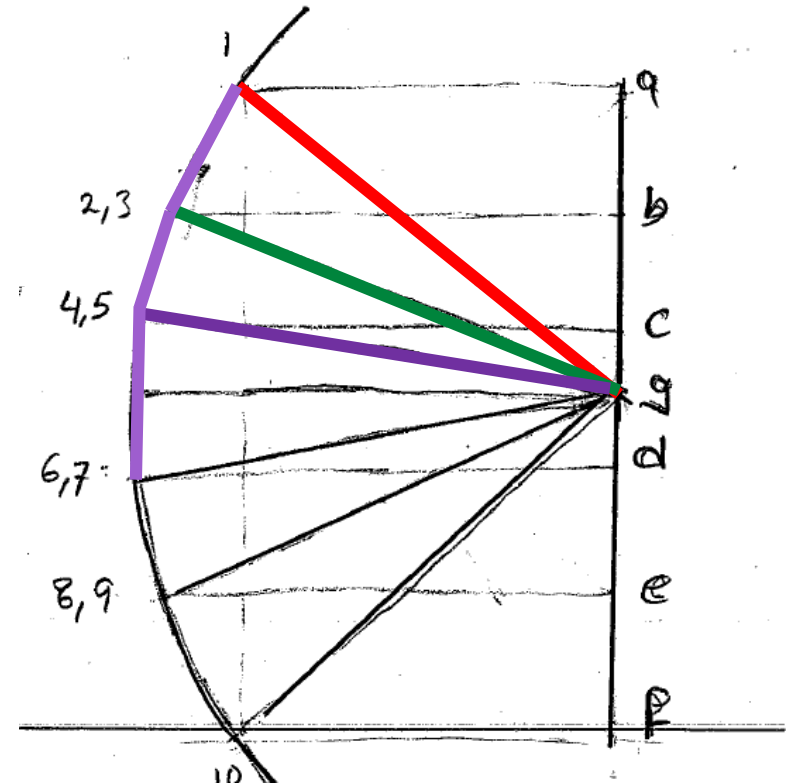

Form Finding and Optimization

How can we find the optimal nodal locations of an arch subject to a maximum compressive force?

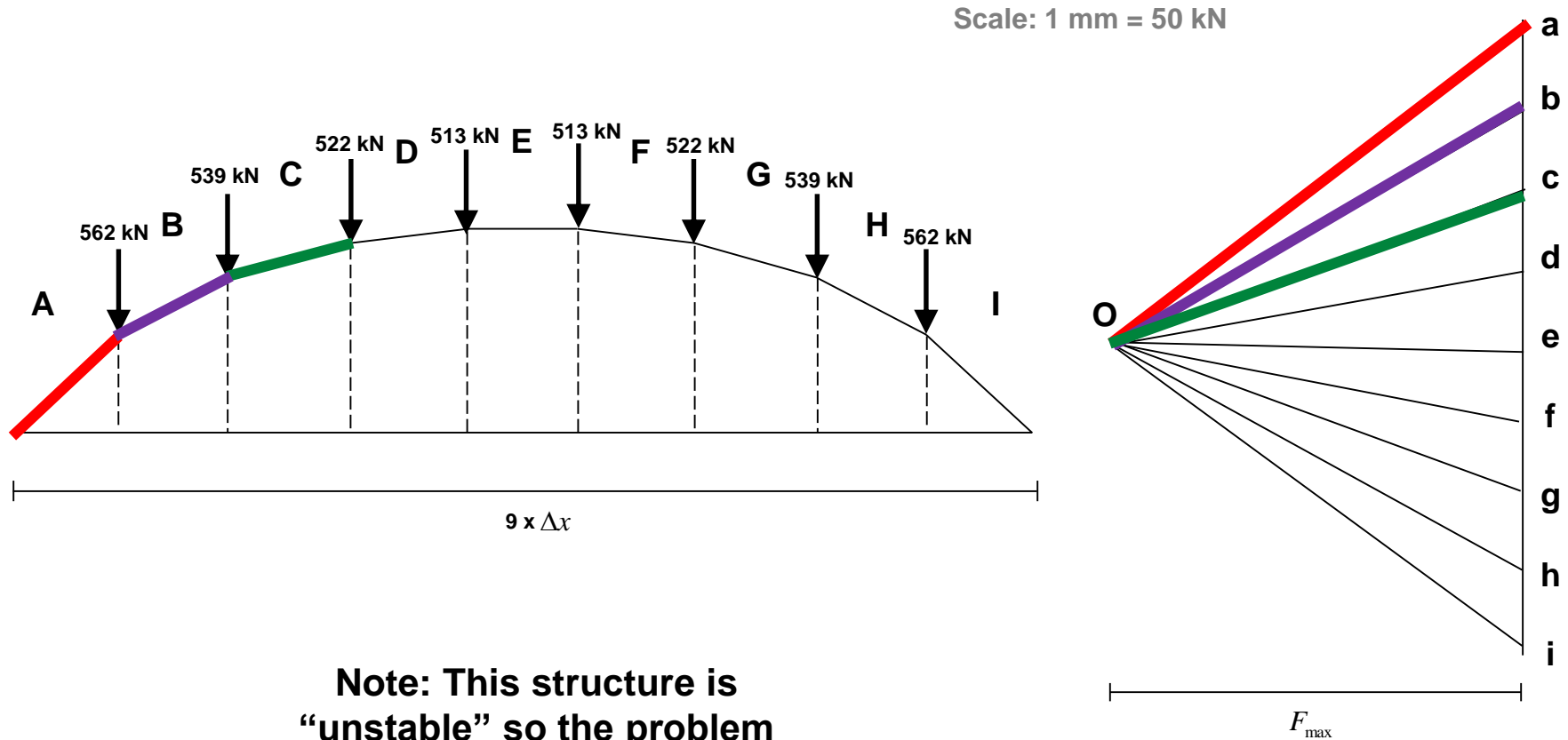

Note: This structure is “unstable” so the problem **cannot** be solved with finite element analysis!

Form Finding and Optimization

How can we find the **nodal locations** of an arch subject to a maximum compressive force?

Scale: 1 mm = 50 kN

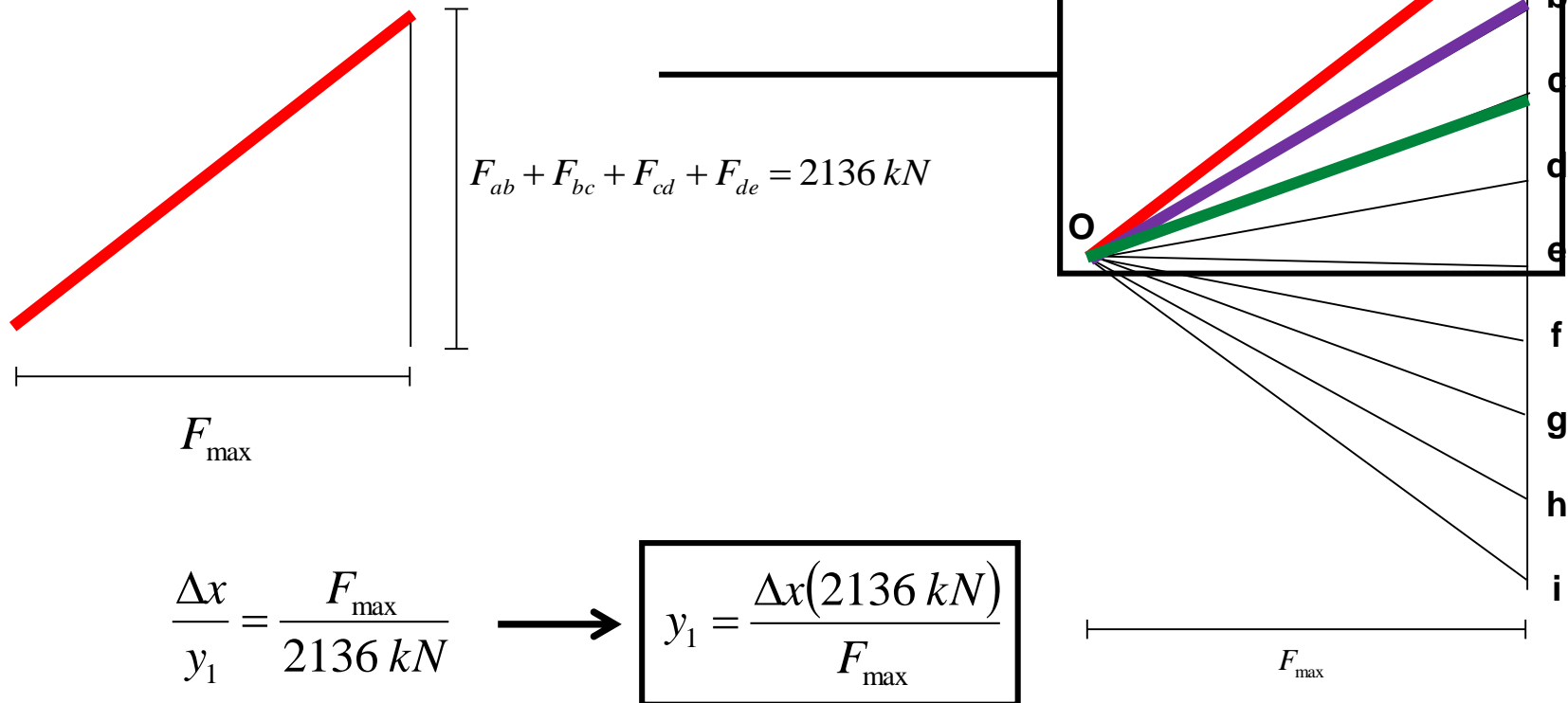

and so on....

Form Finding and Optimization

How can we find the nodal locations of an arch subject to a maximum compressive force?

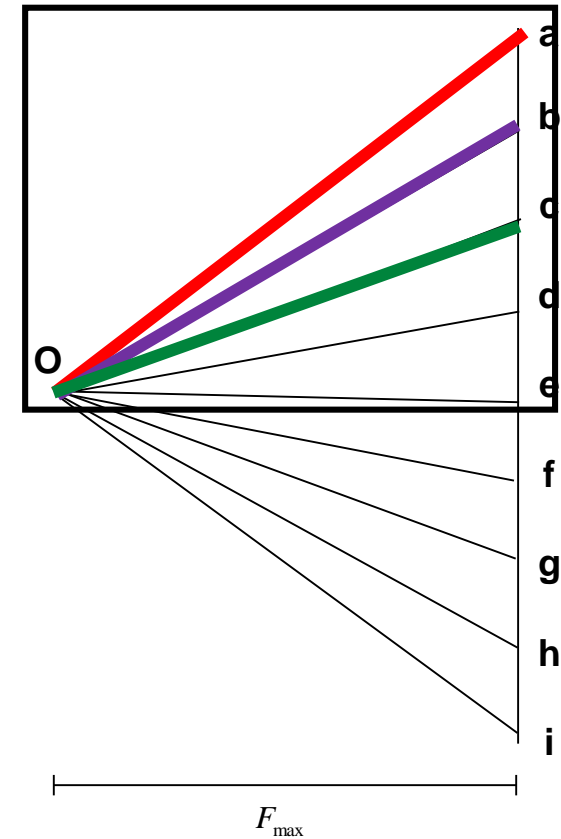
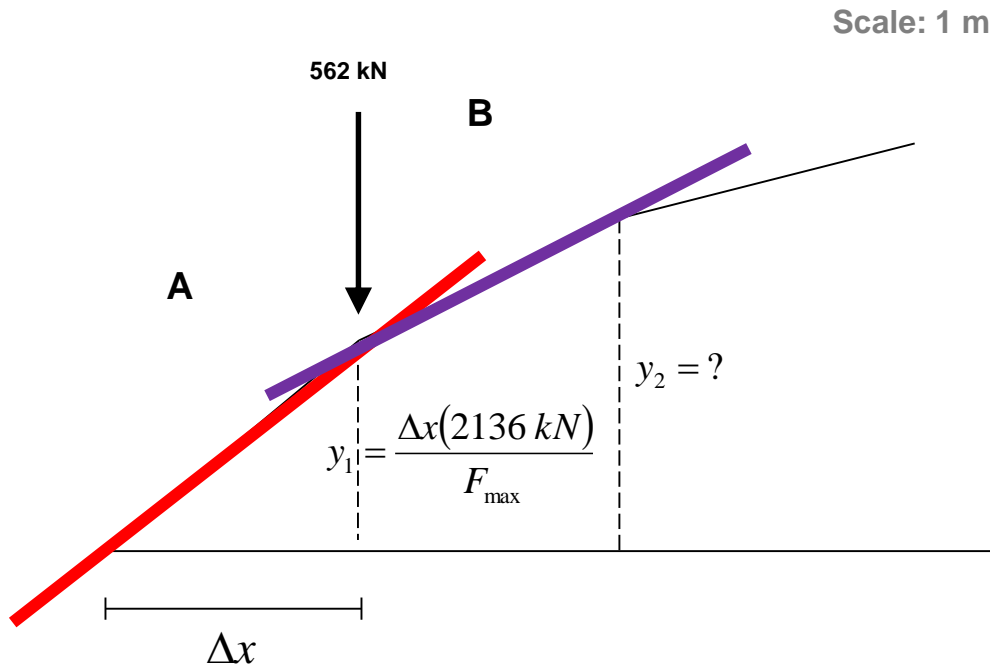

and so on....

Form Finding and Optimization

Robert Maillart's Salginatobel Bridge Design (1928)



Robert Maillart's Key Methods from the Salginatobel Bridge Design Process (1928). Fivet, C
Zastavni, D. (2012). *Journal of the International Association of Shell and Spatial Structures*, 53(1): 39-47.

Form Finding and Optimization

Robert Maillart's Salginatobel Bridge Design (1928)

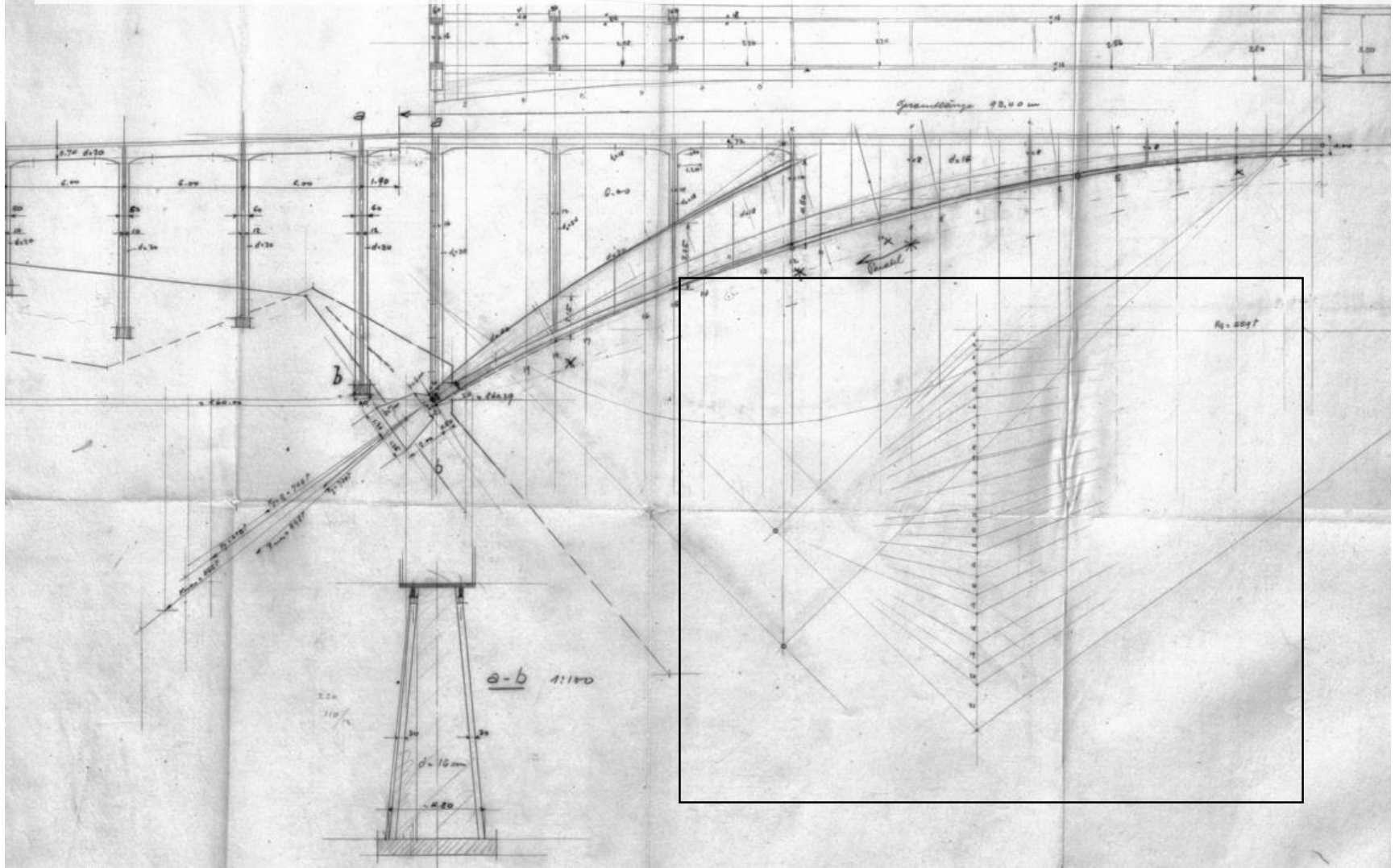

Robert Maillart's Key Methods from the Salginatobel Bridge Design Process (1928). Fivet, C Zastavni, D. (2012). *Journal of the International Association of Shell and Spatial Structures*, 53(1): 39-47.

Form Finding and Optimization

How can we compute the **volume** of a truss?

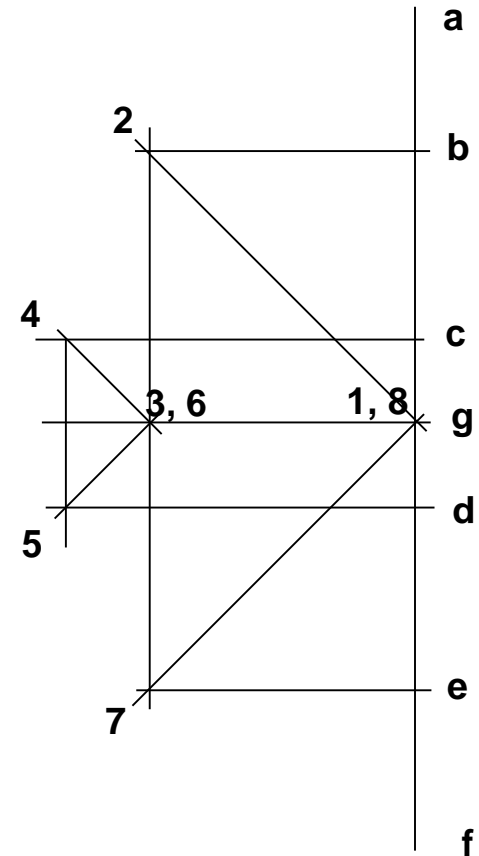
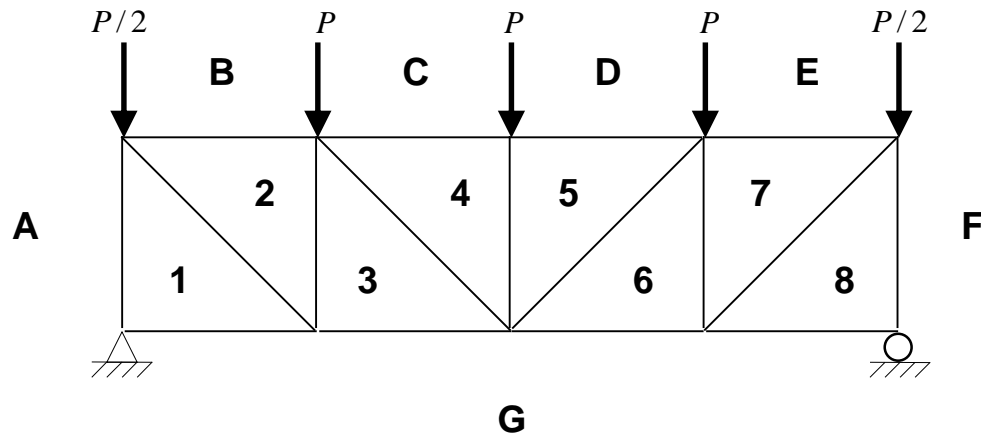

$$V = \sum AL$$
$$= \frac{1}{\sigma} \sum FL$$

*Assuming areas selected
based on constant stress

Form Finding and Optimization

How can we compute the volume of a truss?

L

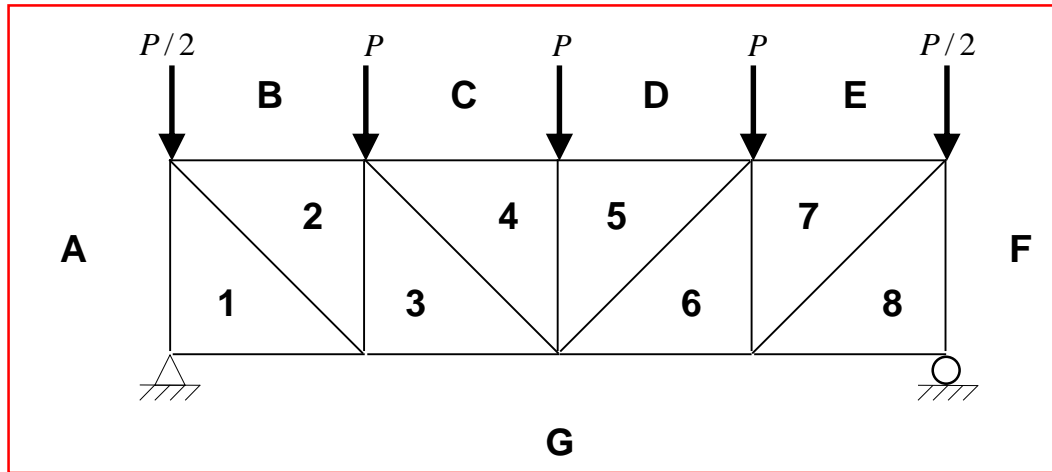

F

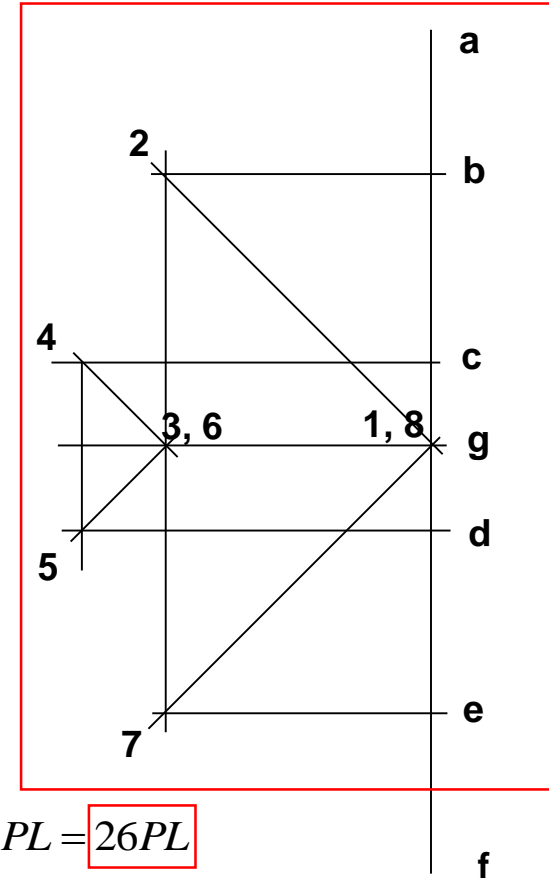

$$\begin{aligned}
 V &= \sum AL \\
 &= \frac{1}{\sigma} \sum FL \\
 &= 2 \times [G-1 + G-3 + B-2 + C-4 + A-1 + 1-2 + 2-3 + 3-4] + 4-5 \\
 &= 2 \times [0 + 1.5PL + 1.5PL + 2PL + 2PL + 3PL + 1.5PL + PL] + PL = 26PL
 \end{aligned}$$

*Assuming areas selected based on constant stress

Form Finding and Optimization

How can we find the geometry for the truss of **minimum volume**?

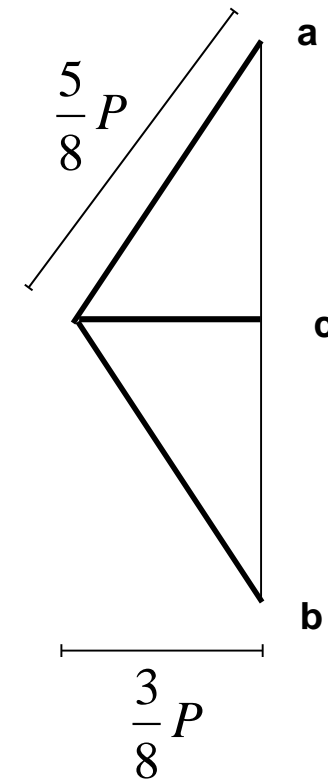
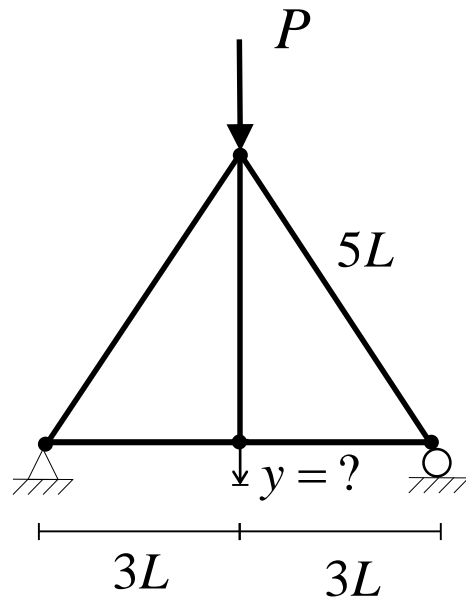

Initial guess: $y = 0$

$$\begin{aligned} V &= \sum AL \\ &= \frac{1}{\sigma} \sum FL \\ &= 2 \times \left[\left(5L \times \frac{5}{8} P \right) + \left(3L \times \frac{3}{8} P \right) \right] = 8.5PL \end{aligned}$$

*Assuming Constant Stress

Form Finding and Optimization

How can we find the geometry for the truss of **minimum volume**?

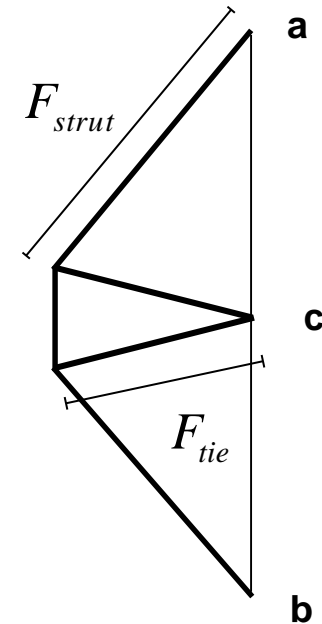
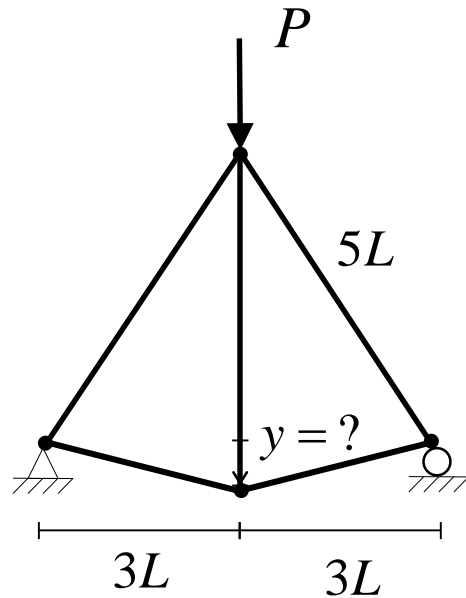

*Assuming Constant Stress

Form Finding and Optimization

How can we find the geometry for the truss of **minimum volume**?

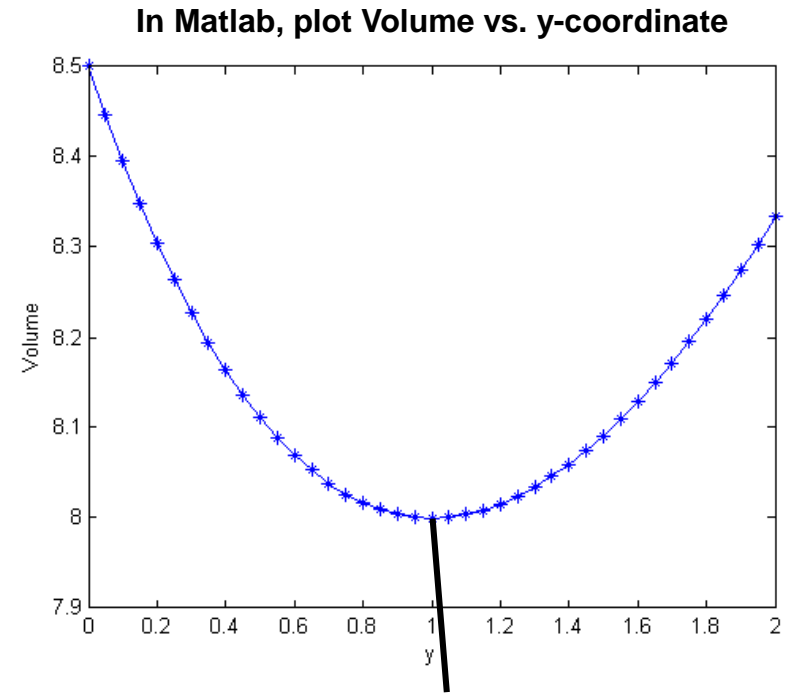
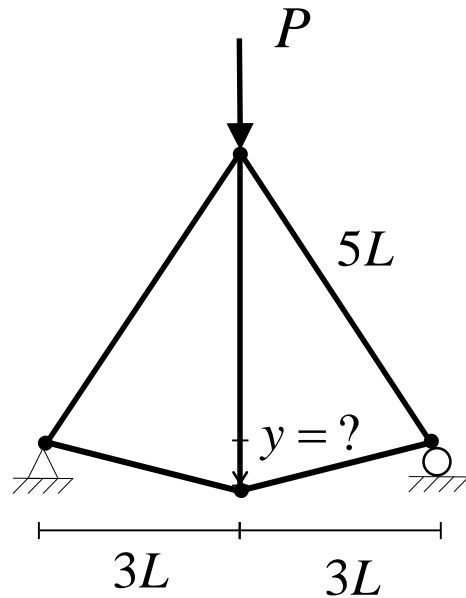

Min. occurs at $y = 1!$

Form Finding and Optimization

How can we find the geometry for the truss of **minimum volume**?

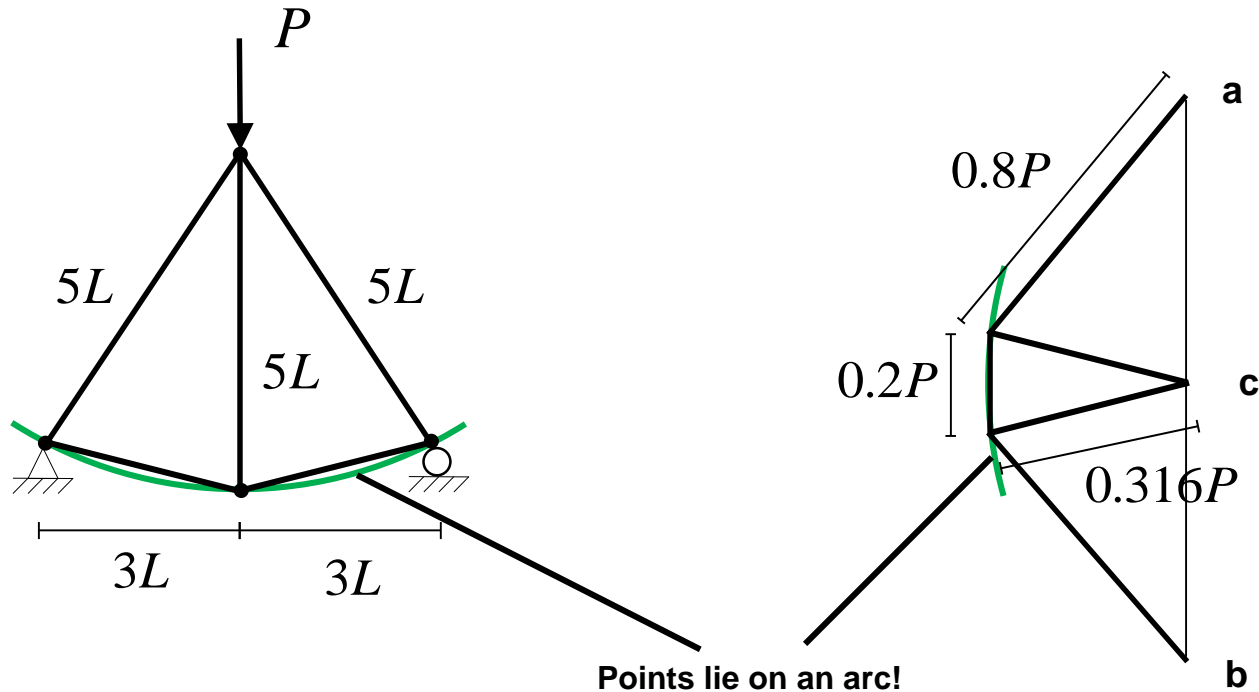

Graphic Statics

An extension: Rankine's Theorem

THEOREM. If lines radiating from a point be drawn parallel to the lines of resistance of the bars of a polygonal frame, then the sides of any polygon whose angles lie in those radiating lines will represent a system of forces, which, being applied to the joints of the frame, will balance each other ; each such force being applied to the joint between the bars whose lines of resistance are parallel to the pair of radiating lines that enclose the side of the polygon of forces, representing the force in question. Also, the lengths of the radiating lines will represent the stresses along the bars to whose lines of resistance they are respectively parallel.

Rankine's Theorem

Graphic Statics

To find the shape of a cable, for any given set of forces in equilibrium:

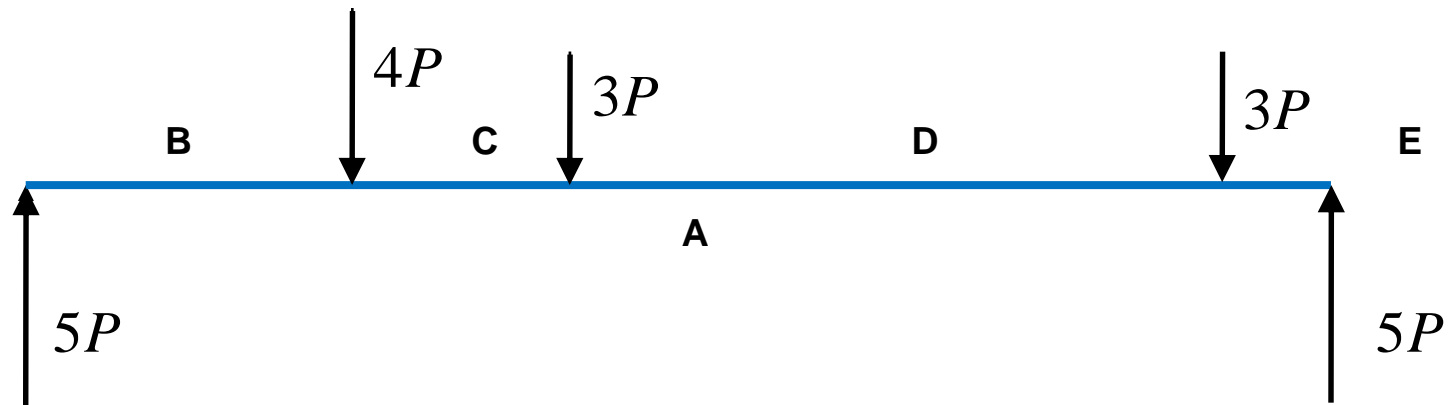

Rankine's Theorem

Graphic Statics

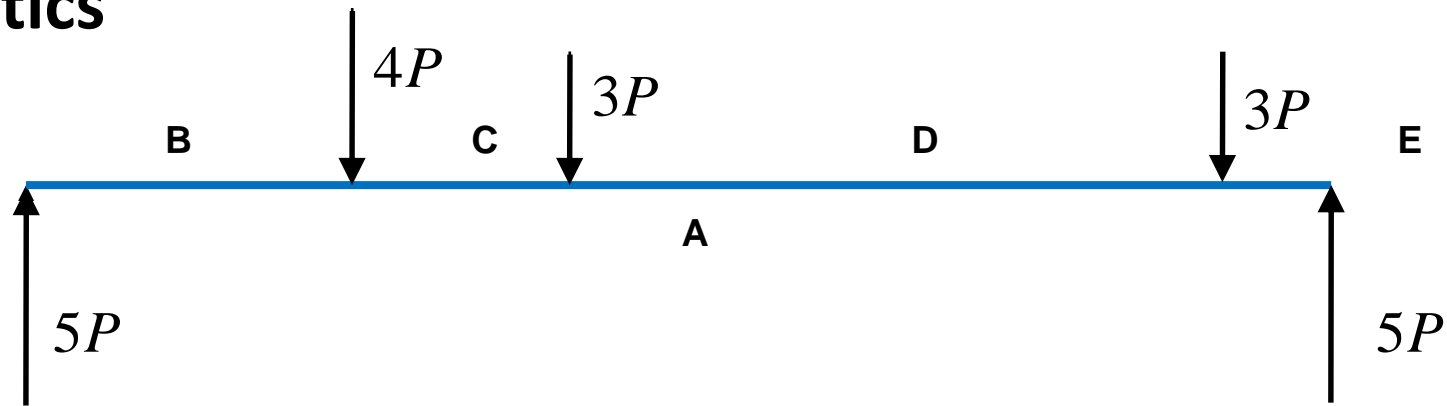

Construct the
External Force
Polygon:

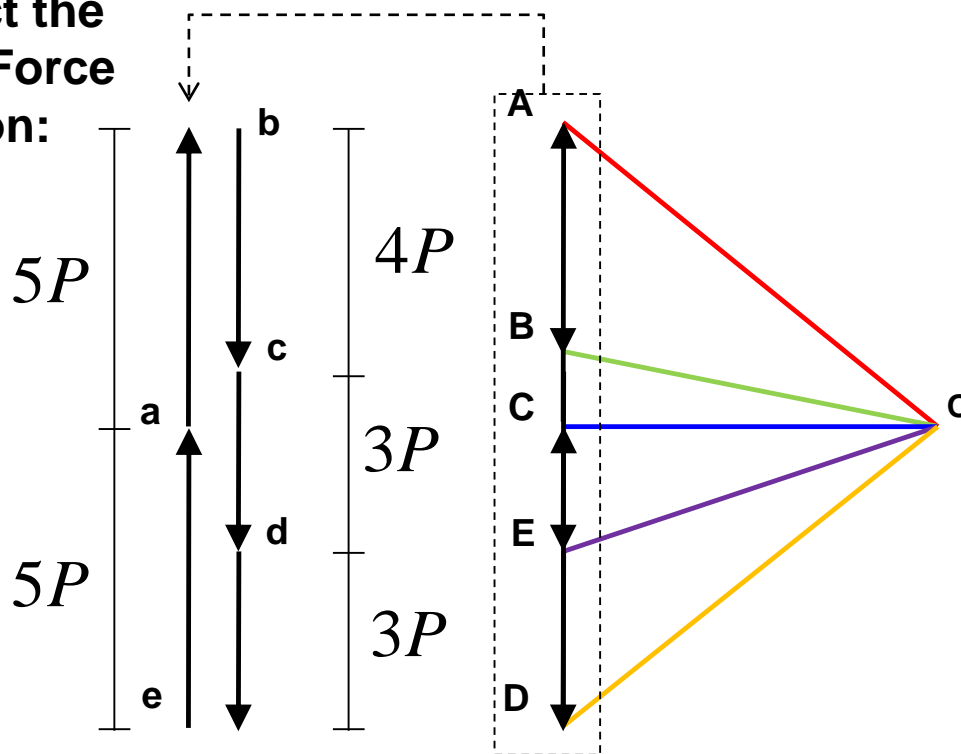

Define an arbitrary origin
'O', and construct rays to
the ends of the force
vectors

Rankine's Theorem

Graphic Statics

Drop lines of action from the forces:

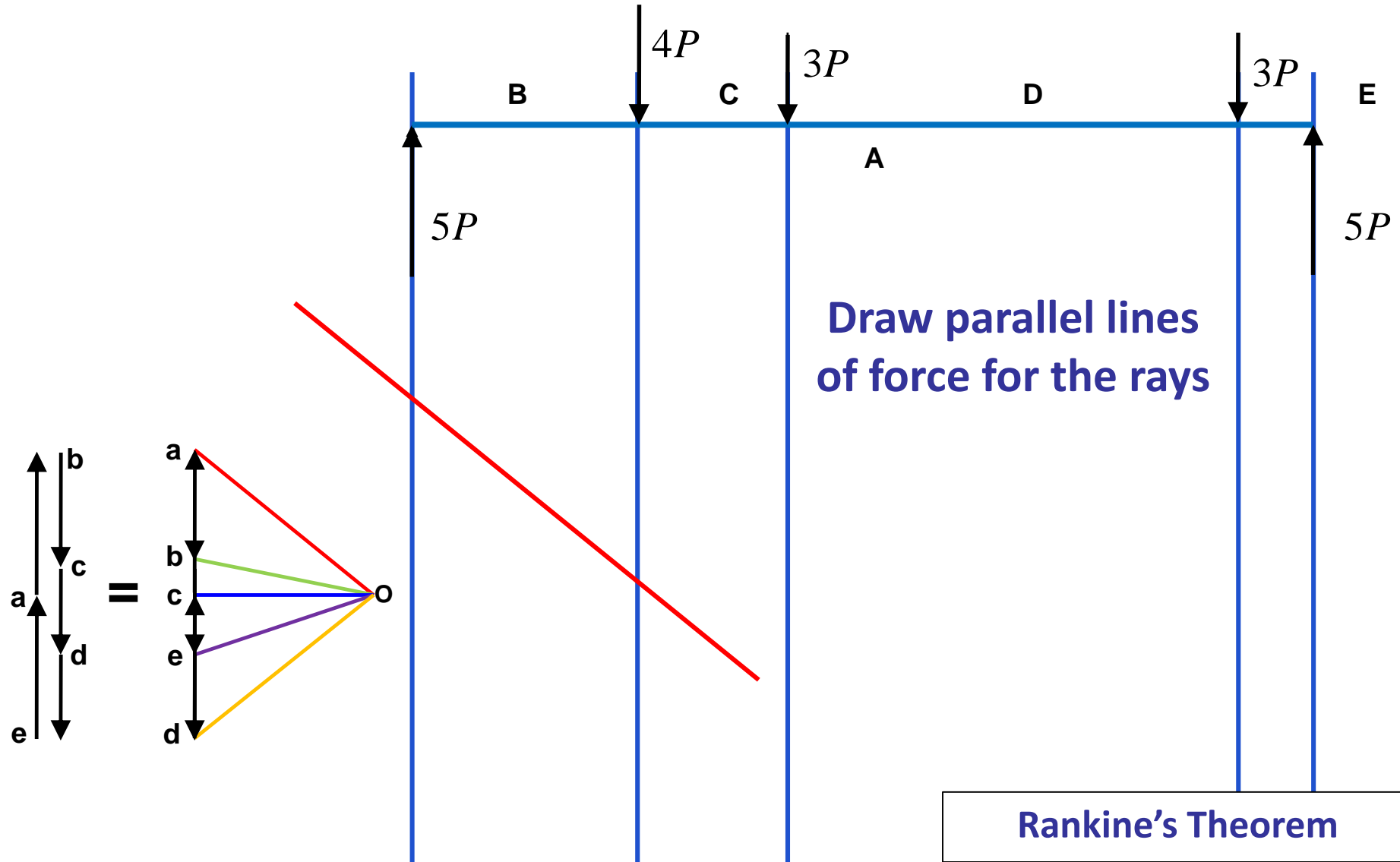

Rankine's Theorem

Graphic Statics

Continue for all rays
and forces

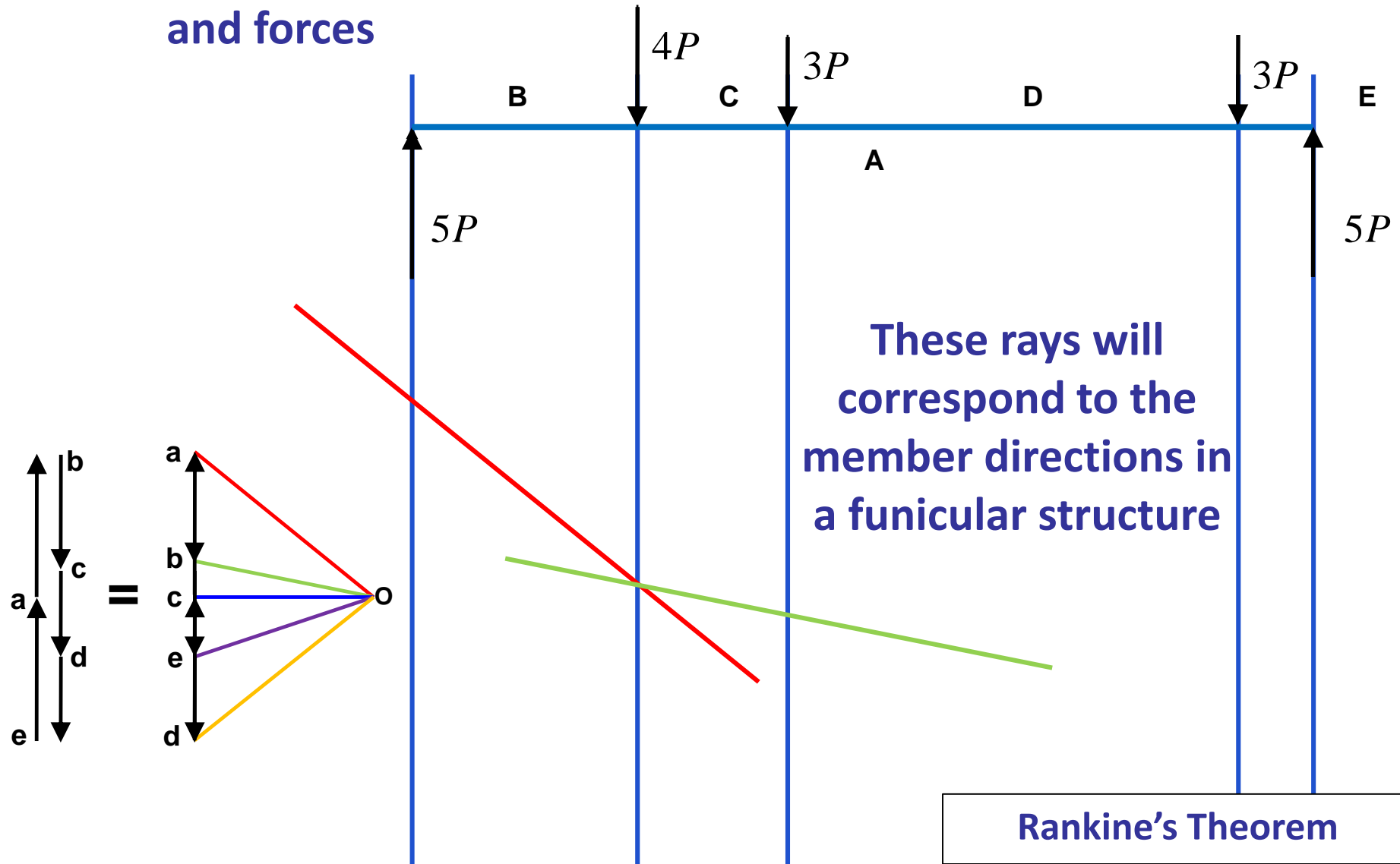

Graphic Statics

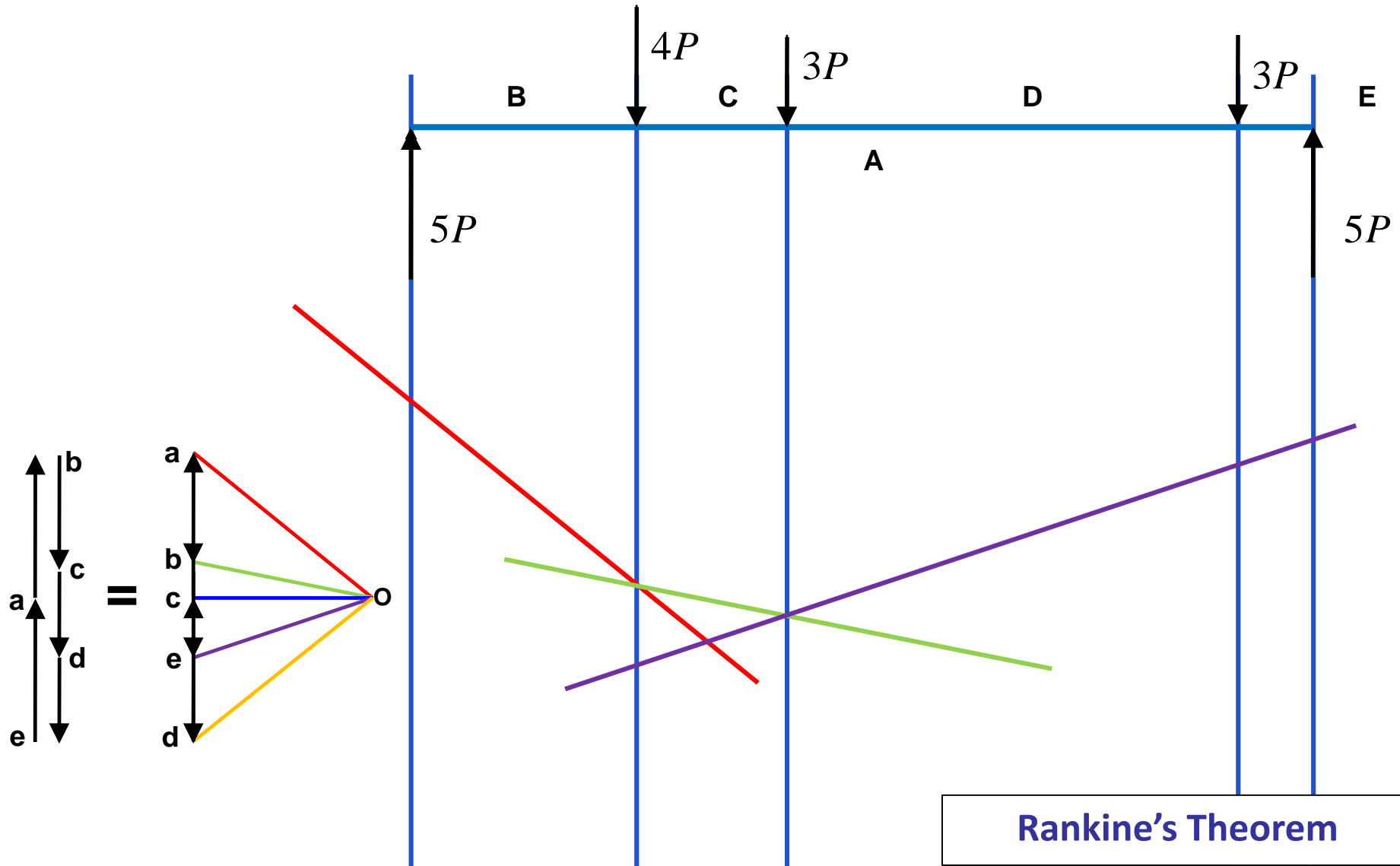

Rankine's Theorem

Graphic Statics

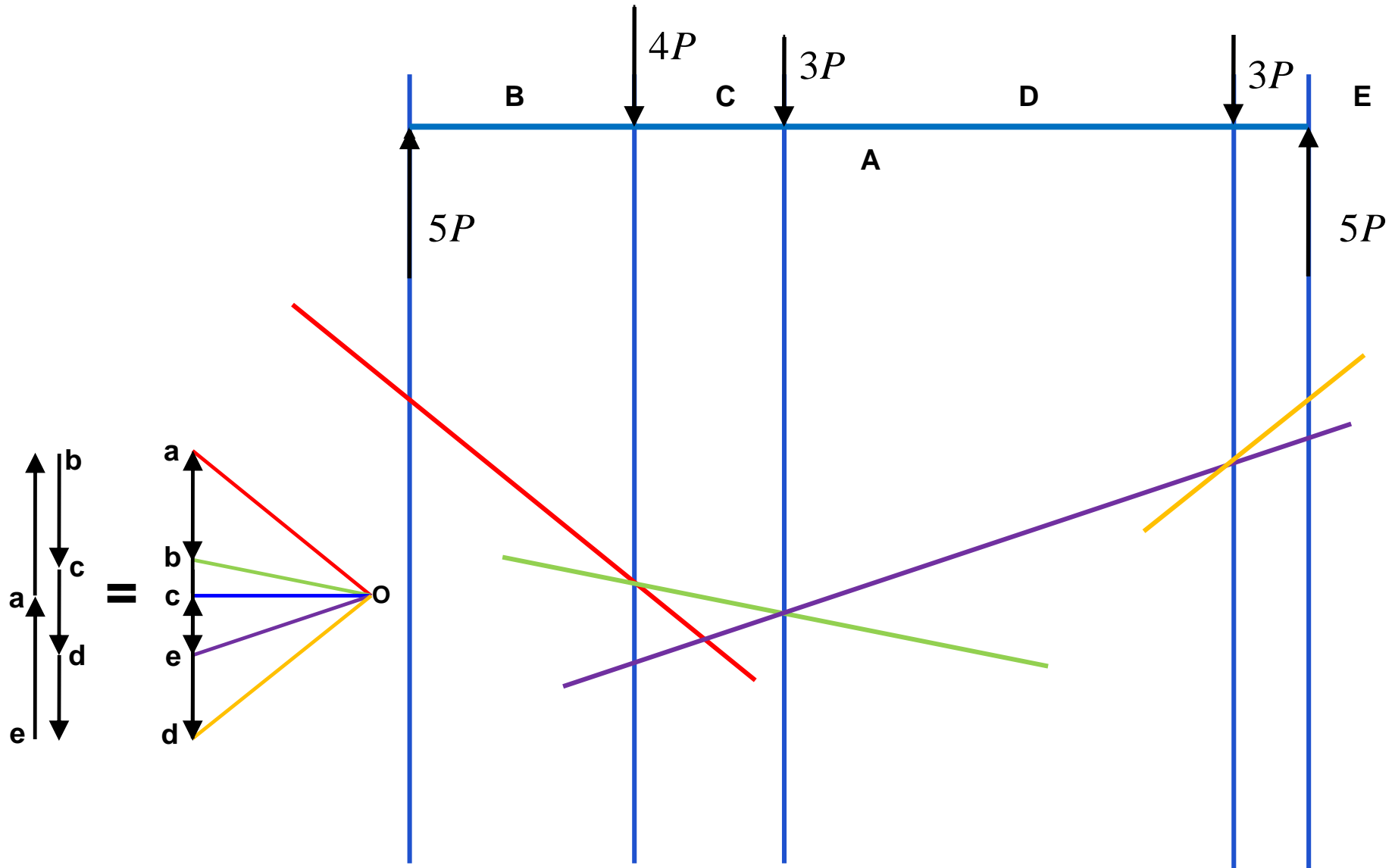

Graphic Statics

The finished funicular polygon

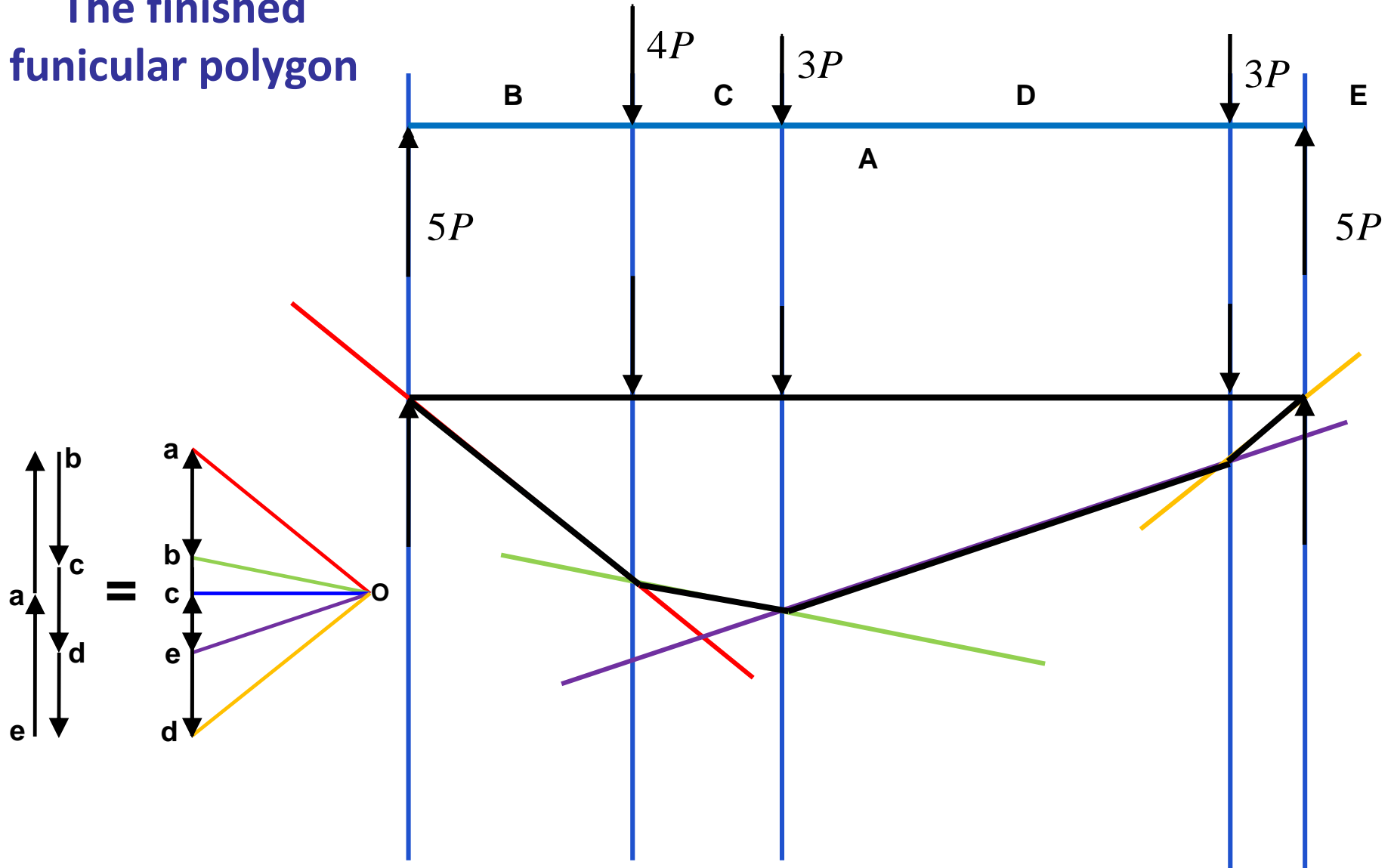

Graphic Statics

Changing the origin changes the shape

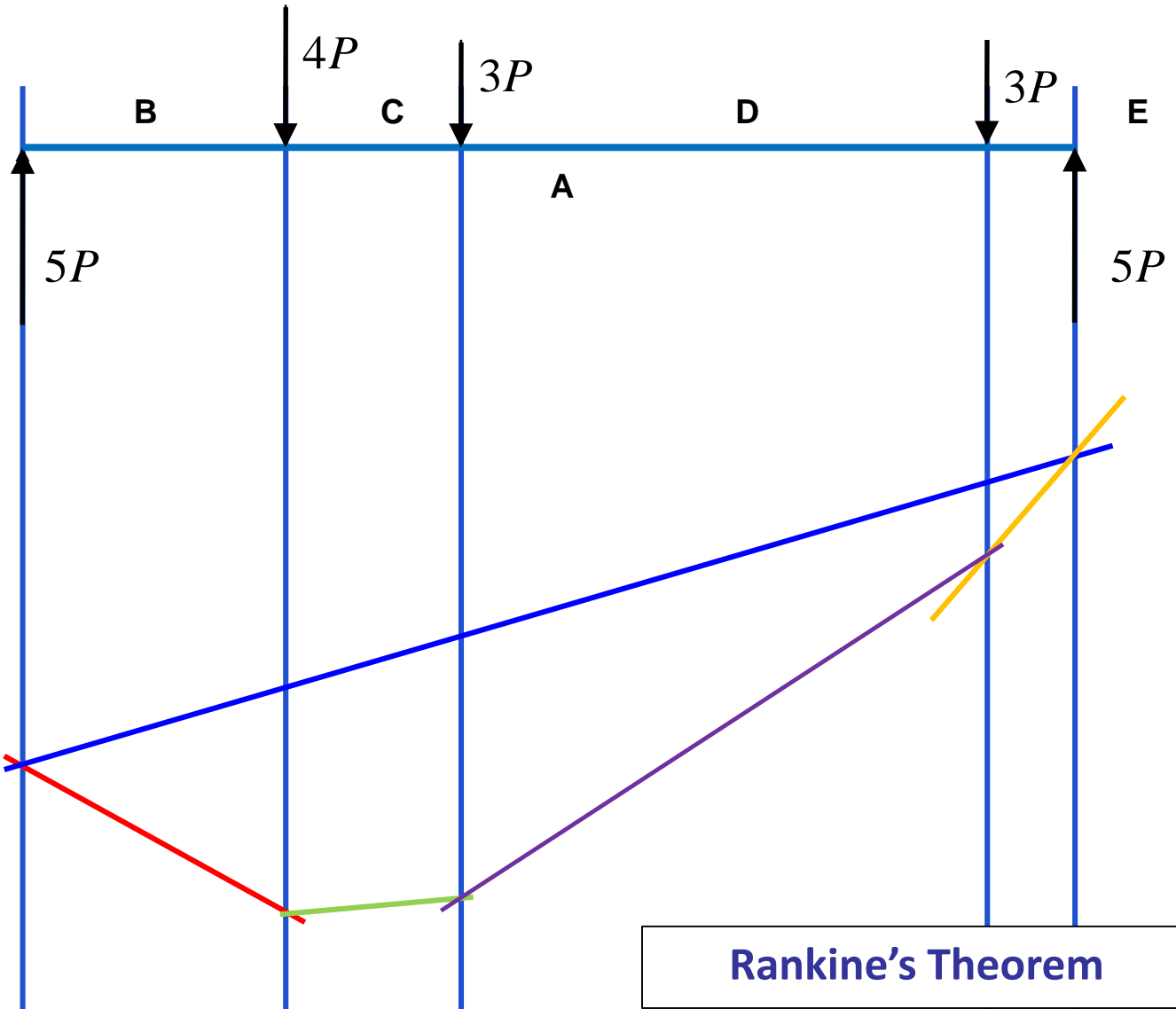
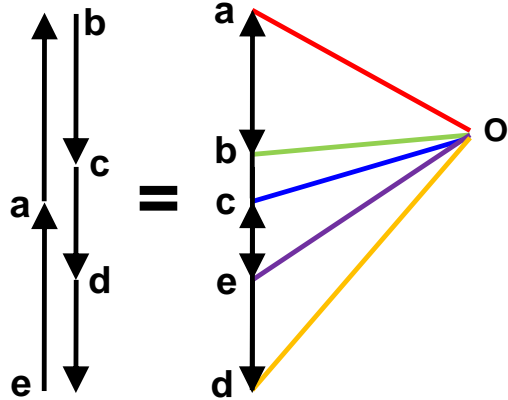

Rankine's Theorem

An aerial, high-angle photograph of a modern architectural structure. The central focus is a large, curved, glass-enclosed volume, possibly a walkway or a large staircase, with a grid-like pattern of glass panels. The structure is surrounded by other parts of a building with a curved, metallic or glass facade. The ground below is a paved area with a green-painted lane, and several cars are visible, suggesting an urban setting. The word "Questions?" is overlaid in a large, white, sans-serif font across the center of the image.

Questions?